

APPENDIX A

Project Location Map

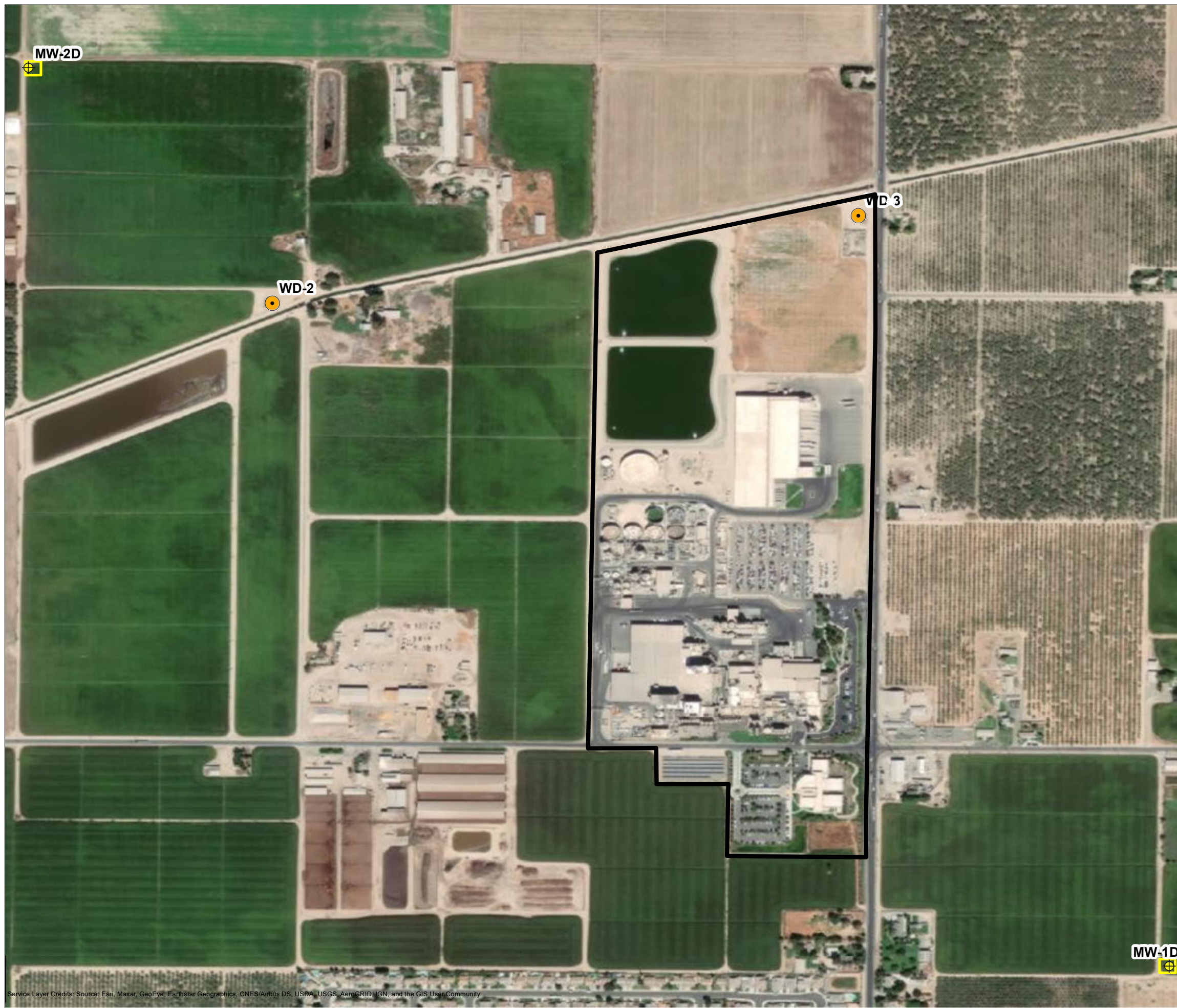



Figure 1, Project Location

UIC Permit R9UIC-CA1-FY15-2R



Service Layer Credits: Source: Esri, Maxar, GeoEye, Earthstar Geographics, CNES/Airbus DS, USDA, USGS, AeroGRID, IGN, and the GIS User Community

LEGEND

-  Hilmar Cheese Facility
-  Injection Well
-  Proposed Monitoring Well
-  Well Pad

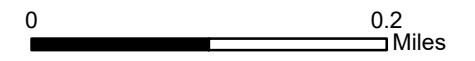

TITLE

Project Location

Hilmar Cheese UIC Permit Renewal

DRAWN BY	APPROVED BY	DATE	FIGURE
KG		2/5/2021	1

APPENDIX B

Well Schematics

WD-2 as-built
WD-3 as-built

MW-1D proposed
MW-2D proposed

UIC Permit R9UIC-CA1-FY15-2R

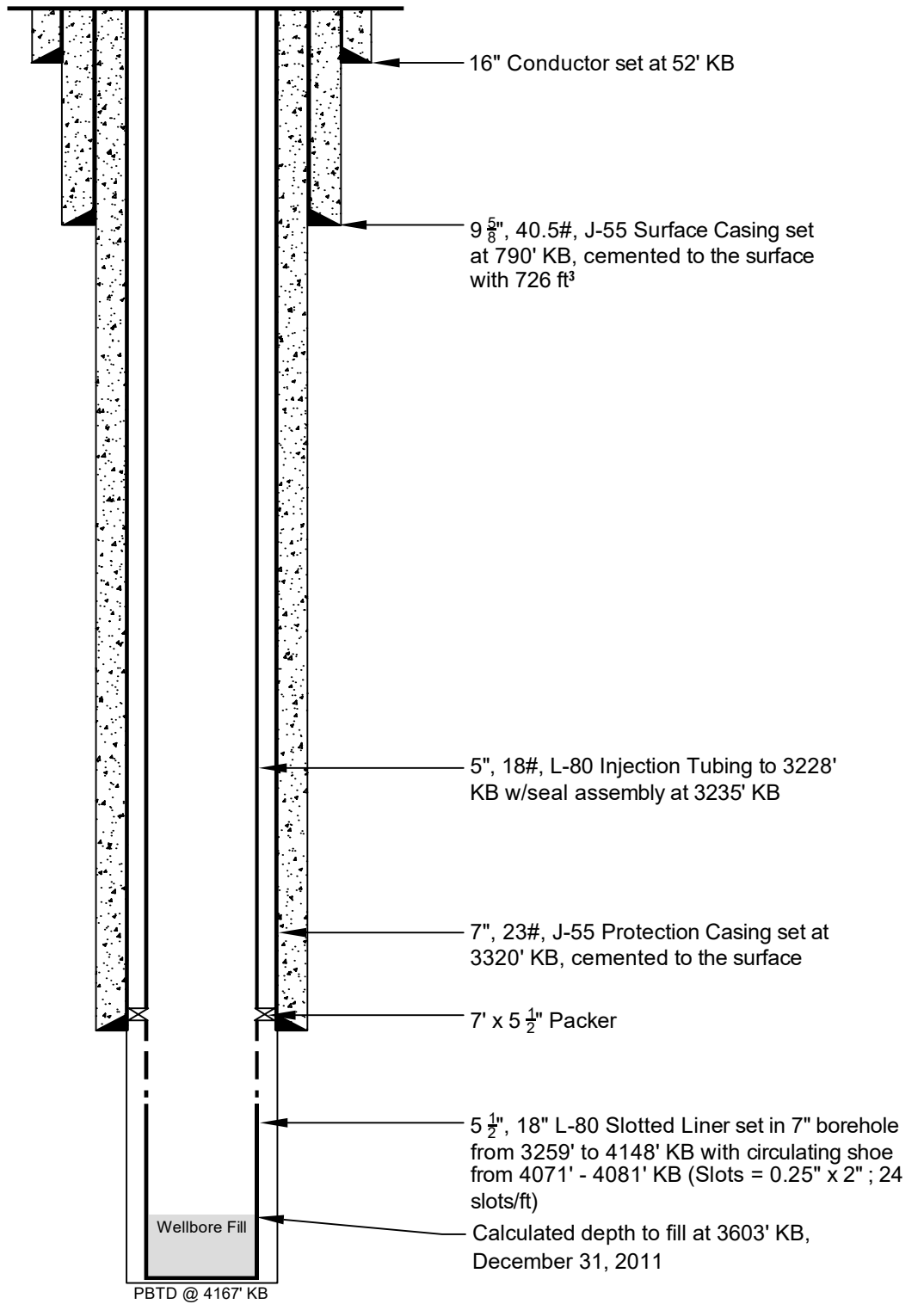

KB= ~95', GL= ~85'



WSP USA Inc.
16200 Park Row Ste. 200
Houston TX 77084
TEL: (281) 589-5900

HILMAR CHEESE COMPANY
HILMAR, CALIFORNIA

WD-2 AS BUILT WELL SCHEMATIC

Job No. 50924A

Design: DB

Drawn: WDD

Checked: SK

Date: 08/13/2021

Scale: NTS

Figure No. Q.2-1

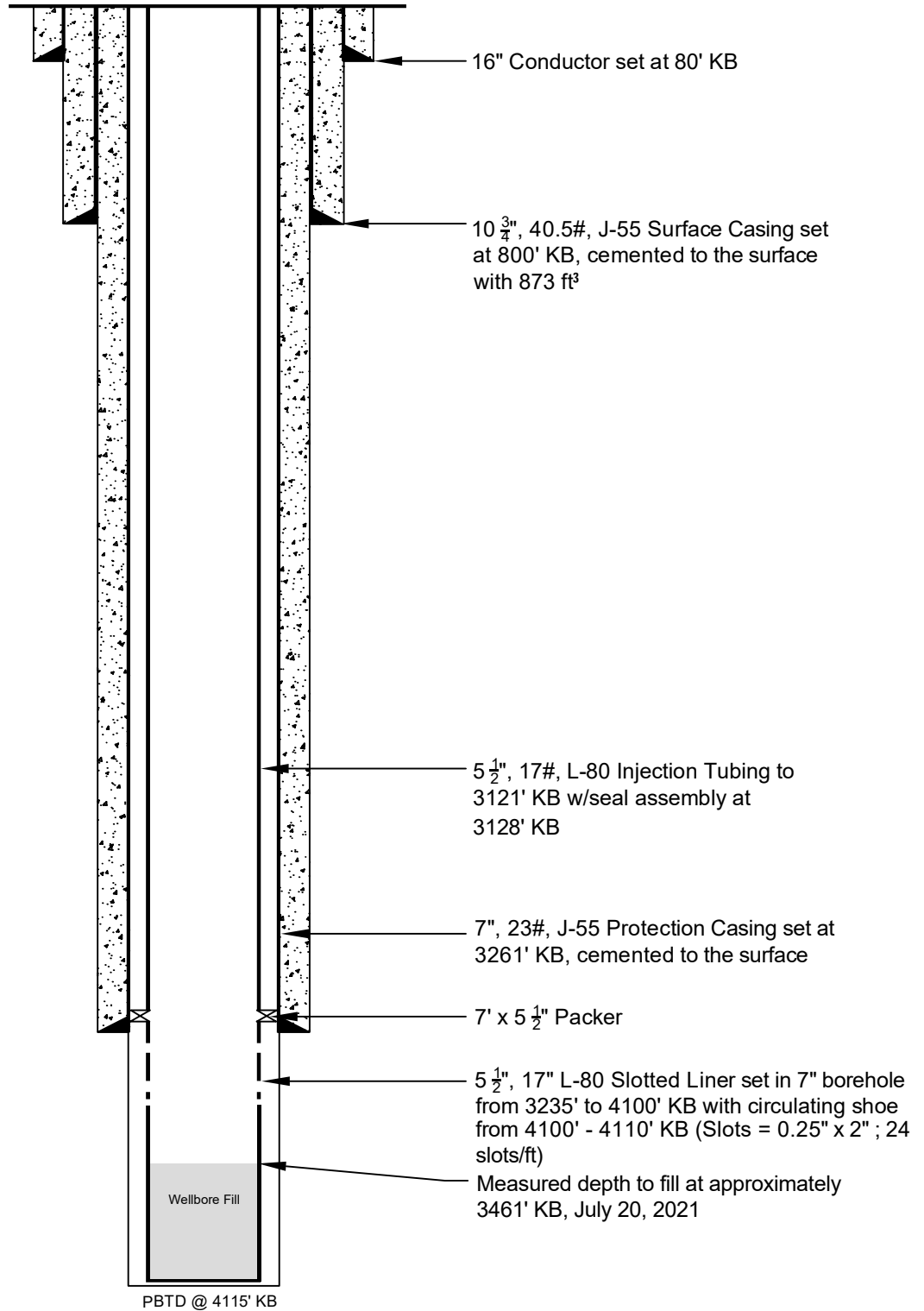

KB= ~105', GL=~92'



WSP USA Inc.
 16200 Park Row Ste. 200
 Houston, TX 77084
 TEL: (281) 589-5900

HILMAR CHEESE COMPANY
HILMAR, CALIFORNIA

WD-3 AS BUILT WELL SCHEMATIC

Job No. 50924A

Design: DB

Drawn: WDD

Checked: SK

Date: 08/13/2021

Scale: NTS

Figure No. Q.3-1

ALL DEPTHS ARE ESTIMATED

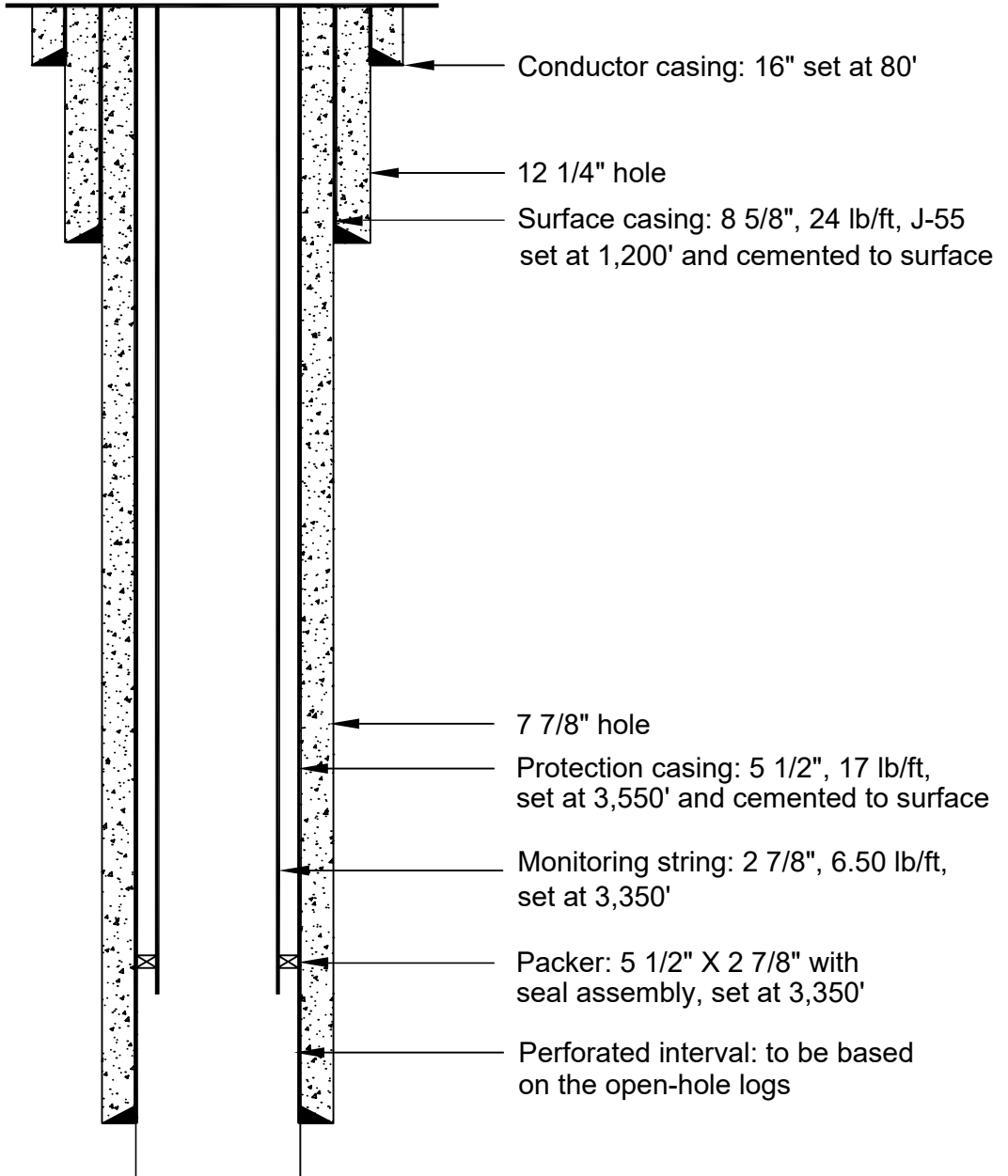

PBTD: 3,600'



HILMAR CHEESE COMPANY
HILMAR, CALIFORNIA

MW-1D PROPOSED WELLBORE SCHEMATIC
MW-2 Proposed Wellbore Schematic

Project No. 192024F

Design:

Drawn:

Checked:

Date: 12/18/2020

Scale: NTS

FIGURE 14-1

ALL DEPTHS ARE ESTIMATED

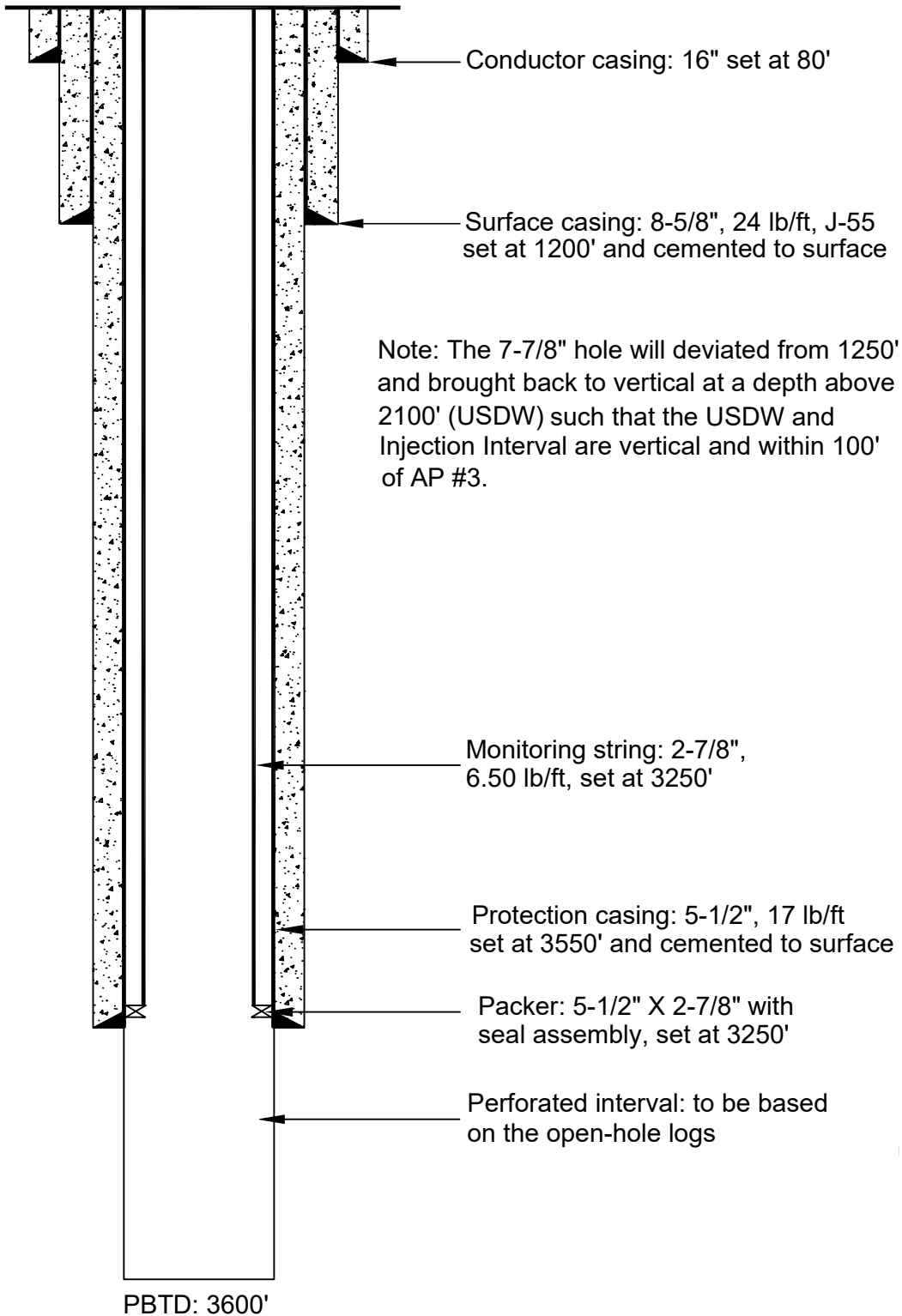

HILMAR CHEESE COMPANY
HILMAR, CALIFORNIA

MW-2D Proposed Wellbore Schematic

Project No. 192024F

Design:

Drawn:

Checked:

Date: 3/11/2021

Scale: NTS

FIGURE 4-2

APPENDIX C

EPA Reporting Forms

UIC Permit R9UIC-CA1-FY15-2R

EPA Reporting Forms List

Form 7520-7: Application to Transfer Permit

Form 7520-8: Quarterly Injection Well Monitoring Report

Form 7520-11: Annual Class II Disposal/Injection Well Monitoring Report

Form 7520-19: Well Rework Record, Plugging and Abandonment Plan, or Plugging and Abandonment Affidavit

These forms are available for downloading at:

<https://www.epa.gov/uic/underground-injection-control-reporting-forms-owners-or-operators>

APPENDIX D

Logging Requirements

Region 9 Radioactive Tracer Survey (RTS) Guidelines

Region 9 Temperature Logging Guidelines

UIC Permit R9UIC-CA1-FY15-2R

UNITED STATES ENVIRONMENTAL PROTECTION AGENCY

REGION 9

RADIOACTIVE TRACER SURVEY (RTS) GUIDELINES

Introduction:

The intent of this guideline document is to provide general guidance to owners and operators of Class I non-hazardous underground injection wells for performing radioactive tracer surveys (RTS) used as a means of testing and measuring the external mechanical integrity of these wells as defined in 40 CFR Part 146.8(a)(2). These guidelines are general in nature and individual well conditions may require deviations from these procedures. All proposed plans and any deviations from these guidelines to conduct radioactive tracer surveys must be approved in advance by the EPA Region 9 Drinking Water Protection Section.

Basic Guidelines:

Prior to commencing performance of the RTS, the operator must have available onsite the following:

- EPA approved plan for conducting the RTS
- Reference Gamma Ray (GR) or Open Hole logs and complete well construction details

The logging company must provide a drawing of their tool configuration with tool diameter, tool length, spacing between detectors, ejector location, casing collar log (CCL), a sketch of the well to be tested construction details and equipment details as part of the logging record.

Tool must include dual GR detectors spaced below the ejector port, centralized with a bow spring centralizer (or motorized centralizer) and be run in conjunction with a CCL.

GR logs are usually run at approximately 60 ft /min. at a time constant of 1 second or 30 ft/min. at a time constant of 2 seconds. Indicate the logging speed and time constant on the logging record. The log scale should preferably correspond with that of the Reference lithology logs that are made available for onsite correlation.

The radioisotope typically utilized for tracer surveys in injection wells is sodium iodine 131 with a half-life of 8.05 days. It is important that the isotope be completely soluble with the injectate fluid.

Example Procedure:

Indicate the beginning and ending clock times on each log pass. Indicate the volume of water injected between log passes. Indicate the volume and concentration of each slug of tracer material and the depth and location of each slug. Where possible, the tracer survey should be conducted utilizing the facility's permitted injectate. If that is not possible, the injected water should have a specific gravity equivalent to that of the facility wastewater and be compatible with the formation and previously injected wastewater. A hydraulically actuated packoff (lubricator) should be utilized even when high well pressures are not expected.

Install the RTS tool with an upper and lower detector and CCL. The RTS tool should be configured to run a standard RTS and to conduct velocity shots. Place the RTS tool in the lubricator and mount lubricator onto the injection wellhead. Open the master valve and slowly start pumping into the well until the desired flow rate is reached.

Radioactive Baseline Survey

1. Run a Correlation GR log with a CCL for 200 to 400 feet at or near the injection interval, provided lithology changes are sufficient for correlation purposes. This will allow equipment to be set on proper depths with the Reference Open Hole or GR logs for the well. The CCL should be run through the packer setting depth and preferably past a short casing joint to collect reference depth information.
2. Run a Base GR log from total depth to approximately 400 feet above the packer setting depth. The log sensitivity should be set such that the slug trace response will take up the entire horizontal log scale in API units. The Base log need not be sensitive enough to show lithology. Record the Total Depth for this initial Base log.
3. Record the injection rate and pressure on the well log record for each log pass. The test should be conducted at the rate corresponding to the Maximum Authorized Injection Pressure (MAIP); however, where the well has been operating at a pressure and rate that are lower than the MAIP, the operator may request approval in advance that the RTS should be run at those operating pressures and rates in which the well normally operates (lower than the MAIP).

Radioactive Tracer Depth Drive Survey

4. Initiate the first slug/ejection with the ejector situated approximately 200 feet above the packer. Record the depth and time, verify ejection of the slug, then drop below the slug and record the time, logging speed, time constant, flow rate, etc. Proceed to make the first logging run up through the slug to above where the slug was initially ejected. Note the time when logging terminated, then again drop past the slug and repeat the logging procedure, each time overlapping the previous log and up to a point where the log returns to baseline. Repeat the

logging sequence until all tracer material has exited the wellbore or has diminished substantial amounts.

Radioactive Tracer Time Drive Survey

5. Initiate a second ejection with the tool set 2 to 5 feet above the injection interval and on time drive. Wait for the pre-calculated Wait-Time to observe whether any vertical migration is occurring. Increase the pump rate to the anticipated operating injection rate and leave on time drive for another 10 to 15 minutes. Note times, flow rates, pressures, and slug depth.

Radioactive Tracer Vertical Migration Survey

6. Initiate a third ejection approximately 200 feet above the packer, then follow the slug to the injection zone using multiple log passes as with the first slug/ejection to check for leakage around the packer.

Radioactive Tracer Velocity Survey

7. These can be performed at this juncture of the testing. First, run a velocity profile over the injection horizon noting injection rate. Make velocity shots of tracer material at recorded intervals while injection is occurring at less than normal or peak pumping rates. Run the gamma ray tool through the injection zone and record injectate across the intervals injected. Increase the well injection rate to maximum or normal pumping rate and repeat velocity shots of tracer material at recorded intervals. Run the GR tool through the injection zone and record injectate across the intervals injected at the higher well pumping rate. The information gathered from the two passes made at different pumping rates will allow flow distribution to be compared at the different rates.

Radioactive Post Tracer Survey

8. After sufficient testing has been done to determine the exit point of the tracer material and for indications of vertical migration, drop to and record this second total depth and run a final Base GR log from total depth to approximately 400 feet above the packer at the same logging speed and sensitivity as with initial base log. These two logs should overlay each other with all the "hot spots" being explainable.

Post Survey Requirements

9. Interpretation of the log must be provided by the logging company on the log itself. The well log heading should be completely filled out with all essential information provided such as well name and number, coordinates, well owner/operator, reference logs, and elevations, etc. documented. The log should

be depicted in a manner that fully describes the operations conducted with explanations inserted to minimize the possibility of misinterpretation. Three copies of the final prints must be forwarded to the EPA Region 9 Groundwater Office within 30 days of the survey. The electronic copy may be provided via mailed storage disk, email or a web accessed site. Courtesy field copies provided to the onsite EPA Inspector are not official records.

10. The operator provides an analytical interpretation of the logging results performed by a qualified analyst. This must include a written description of the procedure, the methodology used to calculate the Wait-Time and conclusions drawn from the test. The submittal must also include a fluid loss profile across the injection interval.

NOTE: The above referenced method for performing a Radioactive Tracer Survey (RTS) is not necessarily prescriptive of how all tests are to be conducted. Each underground injection well presents unique subsurface geological, pressure and injection rate situations which must be properly accounted for when designing specific RTS plans and procedures and approved in advance.

References and Additional Information:

Refer to the following EPA publications for additional information and guidance on running and interpreting radioactive tracer and temperature logs for evaluation of injection well integrity:

- Dr. R. M. McKinley's publication EPA/600/R-94/124, *Temperature, Radioactive Tracer, and Noise Logging for Injection Well Integrity*. It is out of print, but can be downloaded (searched as "600R94124") from the National Service Center for Environmental Publications (NSCEP) site:
<https://www.epa.gov/nscep>
- EPA Region 8 UIC Program Staff Guidance Document at:
<http://www2.epa.gov/sites/production/files/documents/INFO-RATS.pdf>

*Special acknowledgments for additional consultation with:
Texas World Operations, Inc.
Dr. R.M. McKinley*

UNITED STATES ENVIRONMENTAL PROTECTION AGENCY

REGION 9

TEMPERATURE LOGGING GUIDELINES

A Temperature "Decay" Log (two separate temperature logging passes) must satisfy the following criteria to be considered a valid MIT as specified by 40 CFR §146.8(c)(1). Variances to these requirements are expected for certain circumstances, but they must be approved prior to running the log. As a general rule, the well shall inject for approximately six (6) months prior to running a temperature decay progression sequence of logs.

1. With the printed log, also provide raw data for both logging runs (at least one data reading per foot depth) unless the logging truck is equipped with an analog panel as the processing device.
2. The heading on the log must be complete and include all the pertinent information, such as correct well name, location, elevations, etc.
3. The total shut-in times must be clearly shown in the heading. Minimum shut-in time for active injectors is twelve (12) hours for running the initial temperature log, followed by a second log, a minimum of four (4) hours later. These two log runs will be superimposed on the same track for final presentation.
4. The logging speed must be kept between twenty (20) and fifty (50) feet per minute (30 ft/min optimum) for both logs. The temperature sensor should be located as close to the bottom of the tool string as possible (logging downhole).
5. The vertical depth scale of the log should be one (1) or two (2) inches per one hundred (100) feet to match lithology logs (see 7(b)). The horizontal temperature scale should be no more than one Fahrenheit degree per inch spacing.
6. The right-hand tracks must contain the "absolute" temperature and the "differential" temperature curves with both log runs identified and clearly superimposed for comparison and interpretation purposes.
7. The left-hand tracks must contain (unless impractical, but EPA must pre-approve any deviations):
 - (a) a collar locator log,
 - (b) a lithology log which includes either:
 - (i) an historic Gamma Ray that is "readable", i.e. one that demonstrates lithologic changes without either excessive activity by the needle or severely dampened responses;
or
 - (ii) a copy of an original spontaneous potential (SP) curve from either the subject well or from a representative, nearby well.
 - (c) A clear identification on the log showing the base of the lowermost Underground Source of Drinking Water (USDW). A USDW is basically a formation that contains less than ten thousand (10,000) parts per million (ppm) Total Dissolved Solids (TDS) and is further defined in 40 CFR §144.3.

APPENDIX E

EPA Region 9 UIC Pressure Falloff Requirements

UIC Permit R9UIC-CA1-FY15-2R

**EPA Region 9
UIC PRESSURE FALLOFF
REQUIREMENTS**

**Condensed version of the
EPA Region 6
UIC PRESSURE FALLOFF
TESTING GUIDELINE
Third Revision**

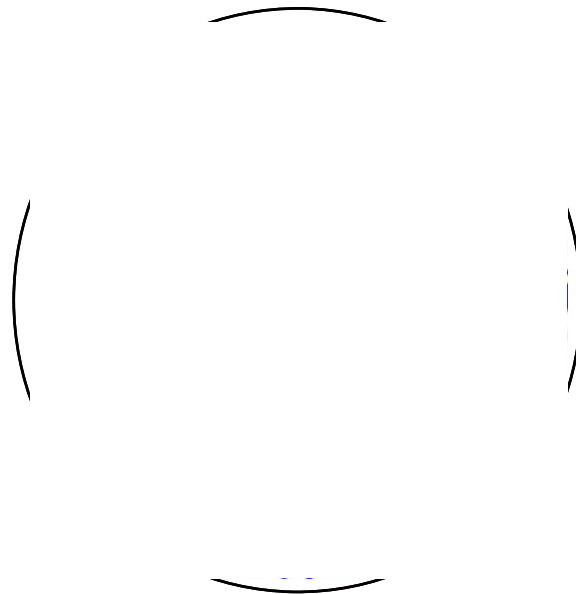

August 8, 2002

TABLE OF CONTENTS

- 1.0 Background
- 2.0 Purpose of Guideline
- 3.0 Timing of Falloff Tests and Report Submission
- 4.0 Falloff Test Report Requirements
- 5.0 Planning
 - General Operational Concerns
 - Site Specific Pretest Planning
- 6.0 Conducting the Falloff Test
- 7.0 Evaluation of the Falloff Test
 - 1. Cartesian Plot
 - 2. Log-log Plot
 - 3. Semilog Plot
 - 4. Anomalous Results
- 8.0 Technical References

APPENDIX

Pressure Gauge Usage and Selection

- Usage
- Selection

Test Design

- General Operational Considerations
- Wellbore and Reservoir Data Needed to Simulate or Analyze the Falloff Test
- Design Calculations
- Considerations for Offset Wells Completed in the Same Interval

Falloff Test Analysis

- Cartesian Plot
- Log-log Diagnostic Plot
- Identification of Test Flow Regimes
- Characteristics of Individual Test Flow Regimes
 - Wellbore Storage
 - Radial Flow
 - Spherical Flow
 - Linear Flow
 - Hydraulically Fractured Well
 - Naturally Fractured Rock
 - Layered Reservoir

Semilog Plot Determination of the Appropriate Time Function for the Semilog Plot
Parameter Calculations and Considerations
Skin
Radius of Investigation
Effective Wellbore Radius
Reservoir Injection Pressure Corrected for Skin Effects
Determination of the Appropriate Fluid Viscosity
Reservoir Thickness
Use of Computer Software
Common Sense Check

REQUIREMENTS

UIC PRESSURE FALLOFF TESTING GUIDELINE

Third Revision

August 8, 2002

1.0 Background

Region 9 has adopted the Region 6 UIC Pressure Falloff Testing Guideline requirements for monitoring Class 1 Non Hazardous waste disposal wells. Under 40 CFR 146.13(d)(1), operators are required annually to monitor the pressure buildup in the injection zone, including at a minimum, a shut down of the well for a time sufficient to conduct a valid observation of the pressure falloff curve.

All of the following parameters (Test, Period, Analysis) are critical for evaluation of technical adequacy of UIC permits:

A falloff **test** is a pressure transient test that consists of shutting in an injection well and measuring the pressure falloff. The falloff **period** is a replay of the injection preceding it; consequently, it is impacted by the magnitude, length, and rate fluctuations of the injection period. Falloff testing **analysis** provides transmissibility, skin factor, and well flowing and static pressures.

2.0 Purpose of Guideline

This guideline has been adopted by the Region 9 office of the Environmental Protection Agency (EPA) to assist operators in **planning and conducting** the falloff test and preparing the **annual monitoring report**.

Falloff tests provide reservoir pressure data and characterize both the injection interval reservoir and the completion condition of the injection well. Both the reservoir parameters and pressure data are necessary for UIC permit demonstrations. Additionally, a valid falloff test is a monitoring requirement under 40 CFR Part 146 for all Class I injection wells.

The ultimate responsibility of conducting a valid falloff test is the task of the operator. Operators should QA/QC the pressure data and test results to confirm that the results “make sense” prior to submission of the report to the EPA for review.

3.0 Timing of Falloff Tests and Report Submission

Falloff **tests** must be conducted annually. The time **interval** for each test should not be less than 9 months or greater than 15 months from the previous test. This will ensure that the tests will be performed at relatively even intervals.

The falloff testing **report** should be submitted no later than 60 days following the test. Failure to submit a falloff test report will be considered a violation and may result in an enforcement action. Any exceptions should be approved by EPA prior to conducting the test.

4.0 Falloff Test Report Requirements

In general, the **report** to EPA should provide:

- (1) general information and an overview of the falloff test,
- (2) an analysis of the pressure data obtained during the test,
- (3) a summary of the test results, and
- (4) a comparison of those results with previously used parameters.

Some of the following operator and well data will not change so once acquired, it can be copied and submitted with each annual report. The **falloff test report** should include the following information:

1. **Company name and address**
2. **Test well name and location**
3. The name and phone number of **the facility contact person**. The contractor contact may be included if approved by the facility in addition to a facility contact person.
4. **A photocopy of an openhole log** (SP or Gamma Ray) through the injection interval illustrating the type of formation and thickness of the injection interval. The entire log is not necessary.
5. **Well schematic** showing the current wellbore configuration and completion information:
 - X Wellbore radius
 - X Completed interval depths
 - X Type of completion (perforated, screen and gravel packed, openhole)
6. **Depth of fill depth and date tagged.**
7. **Offset well information:**
 - X Distance between the test well and offset well(s) completed in the same interval or involved in an interference test
 - X Simple illustration of locations of the injection and offset wells
8. **Chronological listing of daily testing activities.**
9. **Electronic submission of the raw data (time, pressure, and temperature)** from all pressure gauges utilized on CD-ROM. A READ.ME file or the disk label should list all files included and any necessary explanations of the data. A separate file containing any

- edited data used in the analysis can be submitted as an additional file.
10. **Tabular summary of the injection rate or rates preceding the falloff test.** At a minimum, rate information for 48 hours prior to the falloff or for a time equal to twice the time of the falloff test is recommended. If the rates varied and the rate information is greater than 10 entries, the rate data should be submitted electronically as well as a hard copy of the rates for the report. Including a rate vs time plot is also a good way to illustrate the magnitude and number of rate changes prior to the falloff test.
 11. **Rate information from any offset wells completed in the same interval.** At a minimum, the injection rate data for the 48 hours preceding the falloff test should be included in a tabular and electronic format. Adding a rate vs time plot is also helpful to illustrate the rate changes.
 12. **Hard copy of the time and pressure data** analyzed in the report.
 13. **Pressure gauge information:** (See Appendix, page A-1 for more information on pressure gauges)
 - X List all the gauges utilized to test the well
 - X Depth of each gauge
 - X Manufacturer and type of gauge. Include the full range of the gauge.
 - X Resolution and accuracy of the gauge as a % of full range.
 - X Calibration certificate and manufacturer's recommended frequency of calibration
 14. **General test information:**
 - X Date of the test
 - X Time synchronization: A specific time and date should be synchronized to an equivalent time in each pressure file submitted. Time synchronization should also be provided for the rate(s) of the test well and any offset wells.
 - X Location of the shut-in valve (e.g., note if at the wellhead or number of feet from the wellhead)
 15. **Reservoir parameters (determination):**
 - X Formation fluid viscosity, μ_f cp (direct measurement or correlation)
 - X Porosity, ϕ fraction (well log correlation or core data)
 - X Total compressibility, c_t psi^{-1} (correlations, core measurement, or well test)
 - X Formation volume factor, r_{vb}/stb (correlations, usually assumed 1 for water)
 - X Initial formation reservoir pressure - See Appendix, page A-1
 - X Date reservoir pressure was last stabilized (injection history)
 - X Justified interval thickness, h ft - See Appendix, page A-15
 16. **Waste plume:**
 - X Cumulative injection volume into the completed interval
 - X Calculated radial distance to the waste front, r_{waste} ft
 - X Average historical waste fluid viscosity, if used in the analysis, μ_{waste} cp

17. **Injection period:**
 - X Time of injection period
 - X Type of test fluid
 - X Type of pump used for the test (e.g., plant or pump truck)
 - X Type of rate meter used
 - X Final injection pressure and temperature
18. **Falloff period:**
 - X Total shut-in time, expressed in real time and Δt , elapsed time
 - X Final shut-in pressure and temperature
 - X Time well went on vacuum, if applicable
19. **Pressure gradient:**
 - X Gradient stops - for depth correction
20. **Calculated test data:** include all equations used and the parameter values assigned for each variable within the report
 - X Radius of investigation, r_i ft
 - X Slope or slopes from the semilog plot
 - X Transmissibility, kh/μ md-ft/cp
 - X Permeability (range based on values of h)
 - X Calculation of skin, s
 - X Calculation of skin pressure drop, ΔP_{skin}
 - X Discussion and justification of any reservoir or outer boundary models used to simulate the test
 - X Explanation for any pressure or temperature anomaly if observed
21. **Graphs:**
 - X Cartesian plot: pressure and temperature vs. time
 - X Log-log diagnostic plot: pressure and semilog derivative curves. Radial flow regime should be identified on the plot
 - X Semilog and expanded semilog plots: radial flow regime indicated and the semilog straight line drawn
 - X Injection rate(s) vs time: test well and offset wells (not a circular or strip chart)
22. **A copy of the latest radioactive tracer run** and a brief discussion of the results.

5.0 Planning

The **radial flow portion** of the test is the basis for all pressure transient calculations. Therefore the injectivity and falloff portions of the test should be designed not only to reach radial flow, but to sustain a time frame sufficient for analysis of the radial flow period.

General Operational Concerns

- X Adequate storage for the waste should be ensured for the duration of the test

- X Offset wells completed in the same formation as the test well should be shut-in, or at a minimum, provisions should be made to maintain a constant injection rate prior to and during the test
- X Install a crown valve on the well prior to starting the test so the well does not have to be shut-in to install a pressure gauge
- X The location of the shut-in valve on the well should be at or near the wellhead to minimize the wellbore storage period
- X The condition of the well, junk in the hole, wellbore fill or the degree of wellbore damage (as measured by skin) may impact the length of time the well must be shut-in for a valid falloff test. This is especially critical for wells completed in relatively low transmissibility reservoirs or wells that have large skin factors.
- X Cleaning out the well and acidizing may reduce the wellbore storage period and therefore the shut-in time of the well
- X Accurate recordkeeping of injection rates is critical including a mechanism to synchronize times reported for injection rate and pressure data. The elapsed time format usually reported for pressure data does not allow an easy synchronization with real time rate information. Time synchronization of the data is especially critical when the analysis includes the consideration of injection from more than one well.
- X Any unorthodox testing procedure, or any testing of a well with known or anticipated problems, should be discussed with EPA staff prior to performing the test.
- X If more than one well is completed into the same reservoir, operators are encouraged to send at least two pulses to the test well by way of rate changes in the offset well following the falloff test. These pulses will demonstrate communication between the wells and, if maintained for sufficient duration, they can be **analyzed as an interference test** to obtain interwell reservoir parameters.

Site Specific Pretest Planning

1. Determine the time needed to reach radial flow during the injectivity and falloff portions of the test:
 - X Review previous welltests, if available
 - X Simulate the test using measured or estimated reservoir and well completion parameters
 - X Calculate the time to the beginning of radial flow using the empirically-based equations provided in the Appendix. The equations are different for the injectivity and falloff portions of the test with the skin factor influencing the falloff more than the injection period. (See Appendix, page A-4 for equations)
 - X Allow adequate time beyond the beginning of radial flow to observe radial flow so that a well developed semilog straight line occurs. A good rule of thumb is 3 to 5 times the time to reach radial flow to provide adequate radial flow data for analysis.
2. Adequate and consistent injection fluid should be available so that the injection rate into the test well can be held constant prior to the falloff. This rate should be high enough to

produce a measurable falloff at the test well given the resolution of the pressure gauge selected. The viscosity of the fluid should be consistent. Any mobility issues (k/μ) should be identified and addressed in the analysis if necessary.

3. Bottomhole pressure measurements are required. (See Appendix, page A-2 for additional information concerning pressure gauge selection.)
4. Use two pressure gauges during the test with one gauge serving as a backup, or for verification in cases of questionable data quality. The two gauges do not need to be the same type. (See Appendix, page A-1 for additional information concerning pressure gauges.)

6.0 Conducting the Falloff Test

1. Tag and record the depth to any fill in the test well
2. Simplify the pressure transients in the reservoir
 - X Maintain a constant injection rate in the test well prior to shut-in. This injection rate should be high enough and maintained for a sufficient duration to produce a measurable pressure transient that will result in a valid falloff test.
 - X Offset wells should be shut-in prior to and during the test. If shut-in is not feasible, a constant injection rate should be recorded and maintained during the test and then accounted for in the analysis.
 - X Do not shut-in two wells simultaneously or change the rate in an offset well during the test.
3. The test well should be shut-in at the wellhead in order to minimize wellbore storage and afterflow. (See Appendix, page A-3 for additional information.)
4. Maintain accurate rate records for the test well and any offset wells completed in the same injection interval.
5. Measure and record the viscosity of the injectate periodically during the injectivity portion of the test to confirm the consistency of the test fluid.

7.0 Evaluation of the Falloff Test

1. Prepare a **Cartesian plot** of the pressure and temperature versus real time or elapsed time.
 - X Confirm pressure stabilization prior to shut-in of the test well
 - X Look for anomalous data, pressure drop at the end of the test, determine if pressure drop is within the gauge resolution
2. Prepare a **log-log diagnostic plot** of the pressure and semilog derivative. Identify the

flow regimes present in the welltest. (See Appendix, page A-6 for additional information.)

- X Use the appropriate time function depending on the length of the injection period and variation in the injection rate preceding the falloff (See Appendix, page A-10 for details on time functions.)
 - X **Mark the various flow regimes** - particularly the radial flow period
 - X Include the derivative of other plots, if appropriate (e.g., square root of time for linear flow)
 - X If there is no radial flow period, attempt to type curve match the data
3. Prepare a **semilog plot**.
- X Use the appropriate time function depending on the length of injection period and injection rate preceding the falloff
 - X Draw the semilog straight line through the radial flow portion of the plot and obtain the slope of the line
 - X Calculate the transmissibility, kh/μ
 - X Calculate the skin factor, s , and skin pressure drop, ΔP_{skin}
 - X Calculate the radius of investigation, r_i
4. Explain any anomalous results.

8.0 Technical References

1. SPE Textbook Series No. 1, "Well Testing," 1982, W. John Lee
2. SPE Monograph 5, "Advances in Well Test Analysis," 1977, Robert Earlougher, Jr.
3. SPE Monograph 1, "Pressure Buildup and Flow Tests in Wells," 1967, C.S. Matthews and D.G. Russell
4. "Well Test Interpretation In Bounded Reservoirs," Hart's Petroleum Engineer International, Spivey, and Lee, November 1997
5. "Derivative of Pressure: Application to Bounded Reservoir Interpretation," SPE Paper 15861, Proano, Lilley, 1986
6. "Well Test Analysis," Sabet, 1991
7. "Pressure Transient Analysis," Stanislav and Kabir, 1990
8. "Well Testing: Interpretation Methods," Bourdarot, 1996
9. "A New Method To Account For Producing Time Effects When Drawdown Type Curves Are Used To Analyze Pressure Buildup And Other Test Data," SPE Paper 9289, Agarwal, 1980
10. "Modern Well Test Analysis – A Computer-Aided Approach," Roland N. Horne, 1990
11. Exxon Monograph, "Well Testing in Heterogeneous Formations," Tatiana Streltsova, 1987
12. EPA Region 6 Falloff Guidelines
13. "Practical Pressure Gauge Specification Considerations In Practical Well Testing," SPE Paper No. 22752, Veneruso, Ehlig-Economides, and Petitjean, 1991

14. "Guidelines Simplify Well Test Interpretation," Oil and Gas Journal, Ehlig-Economides, Hegeman, and Vik, July 18, 1994
15. Oryx Energy Company, Practical Pressure Transient Testing, G. Lichtenberger and K. Johnson, April 1990 (Internal document)
16. Pressure-Transient Test Design in Tight Gas Formations, SPE Paper 17088, W.J. Lee, October 1987
17. "Radius-of-Drainage and Stabilization-Time Equations," Oil and Gas Journal, H.K. Van Poolen, Sept 14, 1964
18. "Effects of Permeability Anisotropy and Layering On Well Test Interpretation," Hart's Petroleum Engineer International, Spivey, Aly, and Lee, February 1998
19. "Three Key Elements Necessary for Successful Testing," Oil and Gas Journal, Ehlig-Economides, Hegeman, Clark, July 25, 1994
20. "Introduction to Applied Well Test Interpretation," Hart's Petroleum Engineer International, Spivey, and Lee, August 1997
21. "Recent Developments In Well Test Analysis," Hart's Petroleum Engineer International, Stewart, August 1997
22. "Fundamentals of Type Curve Analysis," Hart's Petroleum Engineer International, Spivey, and Lee, September 1997
23. "Identifying Flow Regimes In Pressure Transient Tests," Hart's Petroleum Engineer International, Spivey and Lee, October 1997
24. "Selecting a Reservoir Model For Well Test Interpretation," Hart's Petroleum Engineer International, Spivey, Ayers, Pursell, and Lee, December 1997
27. "Use of Pressure Derivative in Well-Test Interpretation," SPE Paper 12777, SPE Formation Evaluation Journal, Bourdet, Ayoub, and Pirard, June 1989
28. "A New Set of Type Curves Simplifies Well Test Analysis," World Oil, Bourdet, Whittle, Douglas, and Pirard, May 1983

APPENDIX

Pressure Gauge Usage and Selection

Usage

- X EPA recommends that two gauges be used during the test with one gauge serving as a backup.
- X **Downhole pressure measurements** are less noisy and are required.
- X A bottomhole surface readout gauge (SRO) allows tracking of pressures in real time. Analysis of this data can be performed in the field to confirm that the well has reached radial flow prior to ending the test.
- X The derivative function plotted on the log-log plot amplifies noise in the data, so the use of a good pressure recording device is critical for application of this curve.
- X Mechanical gauges should be **calibrated** before and after each test using a dead weight tester.
- X Electronic gauges should also be **calibrated** according to the manufacturer's recommendations. The manufacturer's recommended frequency of calibration, and a copy of the gauge calibration certificate should be provided with the falloff testing report demonstrating this practice has been followed.

Selection

- X The pressures must remain within the range of the pressure gauge. The larger percent of the gauge range utilized in the test, the better. Typical pressure gauge limits are 2000, 5000, and 10000 psi. Note that gauge accuracy and resolution are typically a function of percent of the full gauge range.
- X Electronic downhole gauges generally offer much better resolution and sensitivity than a mechanical gauge but cost more. Additionally, the electronic gauge can generally run for a longer period of time, be programmed to measure pressure more frequently at various intervals for improved data density, and store data in digital form.
- X Resolution of the pressure gauge must be sufficient to measure small pressure changes at the end of the test.

Test Design

General Operational Considerations

- X The injection period controls what is seen on the falloff since the falloff is replay of the injection period. Therefore, the injection period must reach radial flow prior to shut-in of the well in order for the falloff test to reach radial flow
- X Ideally to determine the optimal lengths of the injection and falloff periods, the test should be simulated using measured or estimated reservoir parameters. Alternatively, injection and falloff period lengths can be estimated from empirical equations using assumed reservoir and well parameters.

- X The injection rate dictates the pressure buildup at the injection well. The pressure buildup from injection must be sufficient so that the pressure change during radial flow, usually occurring toward the end of the test, is large enough to measure with the pressure gauge selected.

- X Waste storage and other operational issues require preplanning and need to be addressed prior to the test date. If brine must be brought in for the injection portion of the test, operators should insure that the fluid injected has a consistent viscosity and that there is adequate fluid available to obtain a valid falloff test. The use of the wastestream as the injection fluid affords several distinct advantages:
 1. Brine does not have to be purchased or stored prior to use.
 2. Onsite waste storage tanks may be used.
 3. Plant wastestreams are generally consistent, i.e., no viscosity variations

- X Rate changes cause pressure transients in the reservoir. **Constant rate injection in the test well and any offset wells completed in the same reservoir are critical to simplify the pressure transients in the reservoir.** Any significant injection rate fluctuations at the test well or offsets must be recorded and accounted for in the analysis using superposition.

- X Unless an injectivity test is to be conducted, shutting in the well for an extend period of time prior to conducting the falloff test reduces the pressure buildup in the reservoir and is not recommended.

- X Prior to conducting a test, a crown valve should be installed on the wellhead to allow the pressure gauge to be installed and lowered into the well without any interruption of the injection rate.

- X The wellbore schematic should be reviewed for possible obstructions located in the well that may prevent the use or affect the setting depth of a downhole pressure gauge. The fill depth in the well should also be reported. The fill depth may not only impact the depth of the gauge, but usually prolongs the wellbore storage period and depending on the type of fill, may limit the interval thickness by isolating some of the injection intervals. A wellbore cleanout or stimulation may be needed prior to conducting the test for the test to reach radial flow and obtain valid results.

- X The location of the shut-in valve can impact the duration of the wellbore storage period. The shut-in valve should be located near the wellhead. Afterflow into the wellbore prolongs the wellbore storage period.

- X The area geology should be reviewed prior to conducting the test to determine the thickness and type of formation being tested along with any geological features such as natural fractures, a fault, or a pinchout that should be anticipated to impact the test.

Wellbore and Reservoir Data Needed to Simulate or Analyze the Falloff Test

- X Wellbore radius, r_w - from wellbore schematic

- X Net thickness, h - See Appendix, page A-15
- X Porosity, ϕ - log or core data
- X Viscosity of formation fluid, μ_f - direct measurement or correlations
- X Viscosity of waste, μ_{waste} - direct measurement or correlations
- X Total system compressibility, c_t - correlations, core measurement, or well test
- X Permeability, k - previous welltests or core data
- X Specific gravity of injection fluid, s.g. - direct measurement
- X Injection rate, q - direct measurement

Design Calculations

When simulation software is unavailable the test periods can be estimated from empirical equations. The following are set of steps to calculate the time to reach radial flow from empirically-derived equations:

1. Estimate the wellbore storage coefficient, C (bbl/psi). There are two equations to calculate the wellbore storage coefficient depending on if the well remains fluid filled (positive surface pressure) or if the well goes on a vacuum (falling fluid level in the well):

- a. Well remains fluid filled:

$$C = V_w \cdot c_{waste} \text{ where, } V_w \text{ is the total wellbore volume, bbls}$$

$$c_{waste} \text{ is the compressibility of the injectate, } \text{psi}^{-1}$$

- b. Well goes on a vacuum:

$$C = \frac{V_u}{\frac{\rho \cdot g}{144 \cdot g_c}} \text{ where, } V_u \text{ is the wellbore volume per unit length, bbls/ft}$$

$$\rho \text{ is the injectate density, psi/ft}$$

$$g \text{ and } g_c \text{ are gravitational constants}$$

2. Calculate the time to reach radial flow for both the injection and falloff periods. Two different empirically-derived equations are used to calculate the time to reach radial flow, $t_{radial\ flow}$, for the injectivity and falloff periods:

- a. Injectivity period:

$$t_{radial\ flow} > \frac{(200000 + 12000s) \cdot C}{\frac{k \cdot h}{\mu}} \text{ hours}$$

- b. Falloff period:

$$t_{radial\ flow} > \frac{170000 \cdot C \cdot e^{0.14 \cdot s}}{\frac{k \cdot h}{\mu}} \text{ hours}$$

The wellbore storage coefficient is assumed to be the same for both the injectivity and falloff periods. The skin factor, s, influences the falloff more than the injection period. Use these equations with caution, as they tend to fall apart for a well with a large

permeability or a high skin factor. Also remember, the welltest should not only reach radial flow, but also sustain radial flow for a timeframe sufficient for analysis of the radial flow period. As a rule of thumb, a timeframe sufficient for analysis is 3 to 5 times the time needed to reach radial flow.

3. As an alternative to steps 1 and 2, to look a specific distance “L” into the reservoir and possibly confirm the absence or existence of a boundary, the following equation can be used to estimate the time to reach that distance:

$$t_{boundary} = \frac{948 \cdot \phi \cdot \mu \cdot c_i \cdot L_{boundary}}{k} \text{ hours}$$

where, $L_{boundary}$ = feet to boundary

$t_{boundary}$ = time to boundary, hrs

Again, this is the time to reach a distance “L” in the reservoir. Additional test time is required to observe a fully developed boundary past the time needed to just reach the boundary. As a rule of thumb, to see a fully developed boundary on a log-log plot, allow at least 5 times the time to reach it. Additionally, for a boundary to show up on the falloff, it must first be encountered during the injection period.

4. Calculate the expected slope of the semilog plot during radial flow to see if gauge resolution will be adequate using the following equation:

$$m_{semilog} = \frac{162.6 \cdot q \cdot B}{k \cdot h \cdot \mu}$$

where, q = the injection rate preceding the falloff test, bpd

B = formation volume factor for water, rvb/stb (usually assumed to be 1)

Considerations for Offset Wells Completed in the Same Interval

Rate fluctuations in offset wells create additional pressure transients in the reservoir and complicate the analysis. Always try to simplify the pressure transients in the reservoir. Do not simultaneously shut-in an offset well and the test well. The following items are key considerations in dealing with the impact of offset wells on a falloff test:

- X Shut-in all offset wells prior to the test
- X If shutting in offset wells is not feasible, maintain a constant injection rate prior to and during the test
- X Obtain accurate injection records of offset injection prior to and during the test
- X At least one of the real time points corresponding to an injection rate in an offset well should be synchronized to a specific time relating to the test well
- X **Following the falloff test in the test well, send at least two pulses from the offset well to the test well by fluctuating the rate in the offset well.** The pressure pulses can confirm communication between the wells and can be simulated in the analysis if observed at the test well. The pulses can also be analyzed as an interference test using an Ei type curve.

- X If time permits, conduct an interference test to allow evaluation of the reservoir without the wellbore effects observed during a falloff test.

Falloff Test Analysis

In performing a falloff test analysis, a series of plots and calculations should be prepared to QA/QC the test, identify flow regimes, and determine well completion and reservoir parameters. Individual plots, flow regime signatures, and calculations are discussed in the following sections.

Cartesian Plot

- X The pressure data prior to shut-in of the well should be reviewed on a Cartesian plot to confirm pressure stabilization prior to the test. A well that has reached radial flow during the injectivity portion of the test should have a consistent injection pressure.
- X A Cartesian plot of the pressure and temperature versus real time or elapsed time should be the first plot made from the falloff test data. Late time pressure data should be expanded to determine the pressure drop occurring during this portion of the test. The pressure changes should be compared to the pressure gauges used to confirm adequate gauge resolution existed throughout the test. If the gauge resolution limit was reached, this timeframe should be identified to determine if radial flow was reached prior to reaching the resolution of the pressure gauge. Pressure data obtained after reaching the resolution of the gauge should be treated as suspect and may need to be discounted in the analysis.
- X **Falloff tests conducted in highly transmissive reservoirs** may be more sensitive to the temperature compensation mechanism of the gauge because the pressure buildup response evaluated is smaller. Region 6 has observed cases in which large temperature anomalies were not properly compensated for by the pressure gauge, resulting in erroneous pressure data and an incorrect analysis. For this reason, the Cartesian plot of the temperature data should be reviewed. **Any temperature anomalies should be noted to determine if they correspond to pressure anomalies.**
- X Include the injection rate(s) of the test well 48 hours prior to shut-in on the Cartesian plot to illustrate the consistency of the injection rate prior to shut-in and to determine the appropriate time function to use on the log-log and semilog plots. (See Appendix, page A10 for time function selection)

Log-log Diagnostic Plot

- X Plot the pressure and semilog derivative versus time on a log-log diagnostic plot. Use the appropriate time function based on the rate history of the injection period preceding the falloff. (See Appendix, page A-10 for time function selection) The log-log plot is used to identify regimes in the welltest.

An log-log plot is shown below:

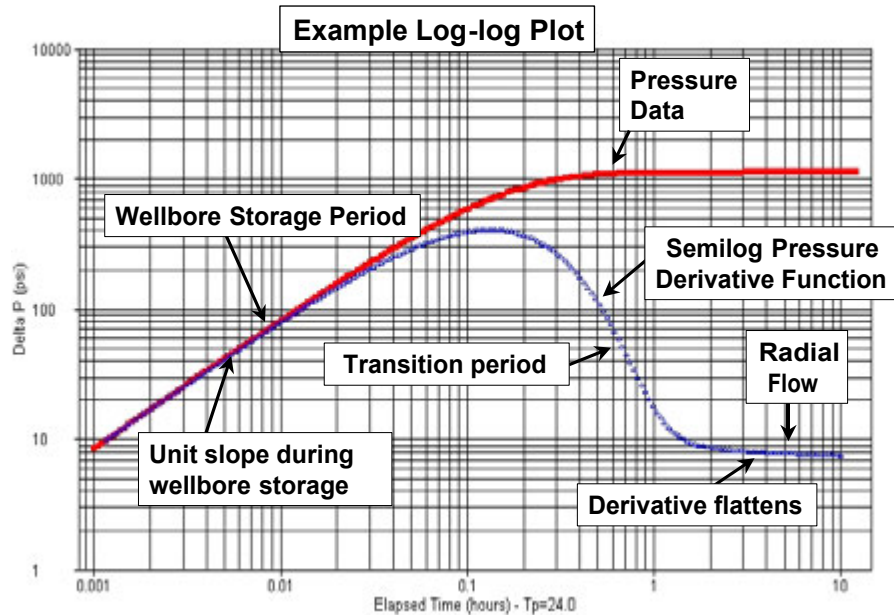

Identification of Test Flow Regimes

- X Flow regimes are mathematical relationships between pressure, rate, and time. Flow regimes provide a visualization of what goes on in the reservoir. Individual flow regimes have characteristic slopes and a sequencing order on the log-log plot.
- X Various flow regimes will be present during the falloff test, however, not all flow regimes are observed on every falloff test. The late time responses correlate to distances further from the test well. **The critical flow regime is radial flow from which all analysis calculations are performed.** During radial flow, the pressure responses recorded are representative of the reservoir, not the wellbore.
- X The derivative function amplifies reservoir signatures by calculating a running slope of a designated plot. The derivative plot allows a more accurate determination of the radial flow portion of the test, in comparison with the old method of simply proceeding 1½ log cycles from the end of the unit slope line of the pressure curve.
- X The derivative is usually based on the semilog plot, but it can also be calculated based on other plots such as a Cartesian plot, a square root of time plot, a quarter root of time plot, and the 1/square root of time plot. Each of these plots are used to identify specific flow regimes. If the flow regime characterized by a specialized plot is present then when the derivative calculated from that plot is displayed on the log-log plot, it will appear as a

“flat spot” during the portion of the falloff corresponding to the flow regime.

X **Typical flow regimes observed on the log-log plot** and their semilog derivative patterns are listed below:

<u>Flow Regime</u>	<u>Semilog Derivative Pattern</u>
Wellbore Storage	Unit slope
Radial Flow	Flat plateau
Linear Flow	Half slope
Bilinear Flow	Quarter slope
Partial Penetration	Negative half slope
Layering	Derivative trough
Dual Porosity	Derivative trough
Boundaries	Upswing followed by plateau
Constant Pressure	Sharp derivative plunge

Characteristics of Individual Test Flow Regimes

X **Wellbore Storage:**

1. Occurs during the early portion of the test and is caused by the well being shut-in at the surface instead of the sandface
2. Measured pressure responses are governed by well conditions and are not representative of reservoir behavior and are characterized by both the pressure and semilog derivative curves overlying a unit slope on the log-log plot
3. Wellbore skin or a low permeability reservoir results in a slower transfer of fluid from the well to the formation, extending the duration of the wellbore storage period
4. A wellbore storage dominated test is unanalyzable

X **Radial Flow:**

1. The pressure responses are from the reservoir, not the wellbore
2. The critical flow regime from which key reservoir parameters and completion conditions calculations are performed
3. Characterized by a flattening of the semilog plot derivative curve on the log-log plot and a straight line on the semilog plot

X **Spherical Flow:**

1. Identifies partial penetration of the injection interval at the wellbore
2. Characterized by the semilog derivative trending along a negative half slope on the log-log plot and a straight line on the 1/square root of time plot
3. The log-log plot derivative of the pressure vs 1/square root of time plot is flat

X **Linear Flow:**

1. May result from flow in a channel, parallel faults, or a highly conductive fracture
2. Characterized by a half slope on both the log-log plot pressure and semilog derivative curves with the derivative curve approximately 1/3 of a log cycle lower than the pressure curve and a straight line on the square root of time plot. 3.
The log-log plot derivative of the pressure vs square root of time plot is flat

X **Hydraulically Fractured Well:**

1. Multiple flow regimes present including wellbore storage, fracture linear flow, bilinear flow, pseudo-linear flow, formation linear flow, and pseudo-radial flow
2. Fracture linear flow is usually hidden by wellbore storage
3. Bilinear flow results from simultaneous linear flows in the fracture and from the formation into the fracture, occurs in low conductivity fractures, and is characterized by a quarter slope on both the pressure and semilog derivative curves on the log-log plot and by a straight line on a pressure versus quarter root of time plot
4. Formation linear flow is identified by a half slope on both the pressure and semilog derivative curves on the log-log plot and by a straight line on a pressure versus square root of time plot
5. Pseudo-radial flow is analogous to radial flow in an unfractured well and is characterized by flattening of semilog derivative curve on the log-log plot and a straight line on a semilog pressure plot

X **Naturally Fractured Rock:**

1. The fracture system will be observed first on the falloff test followed by the total system consisting of the fractures and matrix.
2. The falloff analysis is complex. The characteristics of the semilog derivative trough on the log-log plot indicate the level of communication between the fractures and the matrix rock.

X **Layered Reservoir:**

1. Analysis of a layered system is complex because of the different flow regimes, skin factors or boundaries that may be present in each layer.
2. The falloff test objective is to get a total transmissibility from the **whole reservoir system**.
3. Typically described as commingled (2 intervals with vertical separation) or crossflow (2 intervals with hydraulic vertical communication)

Semilog Plot

- X The semilog plot is a plot of the pressure versus the log of time. There are typically four different semilog plots used in pressure transient and falloff testing analysis. After plotting the appropriate semilog plot, a straight line should be drawn through the points located within the equivalent radial flow portion of the plot identified from the log-log

plot.

- X Each plot uses a different time function depending on the length and variation of the injection rate preceding the falloff. These plots can give different results for the same test, so it is important that the appropriate plot with the correct time function is used for the analysis. Determination of the appropriate time function is discussed below.
- X The slope of the semilog straight line is then used to calculate the reservoir transmissibility - kh/μ , the completion condition of the well via the skin factor - s , and also the radius of investigation - r_i of the test.

Determination of the Appropriate Time Function for the Semilog Plot

The following four different semilog plots are used in pressure transient analysis:

1. Miller Dyes Hutchinson (MDH) Plot
2. Horner Plot
3. Agarwal Equivalent Time Plot
4. Superposition Time Plot

These plots can give different results for the same test. Use of the appropriate plot with the correct time function is critical for the analysis.

- X The **MDH plot** is a semilog plot of pressure versus Δt , where Δt is the elapsed shut-in time of the falloff.
 1. The MDH plot only applies to wells that reach psuedo-steady state during injection. Psuedo-steady state means the pressure response from the well has encountered all the boundaries around the well.
 2. The MDH plot is only applicable to injection wells with a *very* long injection period at a constant rate. This plot is not recommended for use by EPA Region 6.
- X The **Horner plot** is a semilog plot of pressure versus $(t_p+\Delta t)/\Delta t$. The Horner plot is only used for a falloff preceded by a single constant rate injection period.
 1. The injection time, $t_p=V_p/q$ in hours, where V_p =injection volume since the last pressure equalization and q is the injection rate prior to shut-in for the falloff test. The injection volume is often taken as the cumulative injection since completion.
 2. The Horner plot can result in significant analysis error if the injection rate varies prior to the falloff.
- X The **Agarwal equivalent time plot** is a semilog plot of the pressure versus Agarwal equivalent time, Δt_e .
 1. The Agarwal equivalent time function is similar to the Horner plot, but scales the falloff to make it look like an injectivity test.
 2. It is used when the injection period is a short, constant rate compared to the length of the falloff period.
 3. The Agarwal equivalent time is defined as: $\Delta t_e=\log(t_p \Delta t)/(t_p+\Delta t)$, where t_p is calculated the same as with the Horner plot.

- X The **superposition time function** accounts for variable rate conditions preceding the falloff.
1. It is the most rigorous of all the time functions and is usually calculated using welltest software.
 2. The use of the superposition time function requires the operator to accurately track the rate history. As a rule of thumb, at a minimum, the rate history for twice the length of the falloff test should be included in the analysis.

The determination of which time function is appropriate for the plotting the welltest on semilog and log-log plots depends on available rate information, injection period length, and software:

1. If there is not a rate history other than a single rate and cumulative injection, use a Horner time function
2. If the injection period is shorter than the falloff test and only a single rate is available, use the Agarwal equivalent time function
3. If you have a variable rate history use superposition when possible. As an alternative to superposition, use Agarwal equivalent time on the log-log plot to identify radial flow. The semilog plot can be plotted in either Horner or Agarwal time if radial flow is observed on the log-log plot.

Parameter Calculations and Considerations

- X Transmissibility - The slope of the semilog straight line, m , is used to determine the transmissibility (kh/μ) parameter group from the following equation:

$$\frac{k \cdot h}{\mu} = \frac{162.6 \cdot q \cdot B}{m}$$

where, q = injection rate, bpd (negative for injection)

B = formation volume factor, rvb/stb (Assumed to be 1 for formation fluid)

m = slope of the semilog straight line through the radial flow portion of the plot in psi/log cycle

k = permeability, md

h = thickness, ft (See Appendix, page A-15)

μ = viscosity, cp

- X The viscosity, μ , is usually that of the formation fluid. However, if the waste plume size is massive, the radial flow portion of the test may remain within the waste plume. (See Appendix, page A-14)
1. The waste and formation fluid viscosity values usually are similar, however, if the wastestream has a significant viscosity difference, the size of the waste plume and distance to the radial flow period should be calculated.
 2. The mobility, k/μ , differences between the fluids may be observed on the derivative curve.

- X The permeability, k , can be obtained from the calculated transmissibility (kh/μ) by substituting the appropriate thickness, h , and viscosity, μ , values.

Skin Factor

- X In theory, wellbore skin is treated as an infinitesimally thin sheath surrounding the wellbore, through which a pressure drop occurs due to either damage or stimulation. Industrial injection wells deal with a variety of waste streams that alter the near wellbore environment due to precipitation, fines migration, ion exchange, bacteriological processes, and other mechanisms. It is reasonable to expect that this alteration often exists as a zone surrounding the wellbore and not a skin. Therefore, at least in the case of industrial injection wells, the assumption that skin exists as a thin sheath is not always valid. This does not pose a serious problem to the correct interpretation of falloff testing except in the case of a large zone of alteration, or in the calculation of the flowing bottomhole pressure. Region 6 has seen instances in which large zones of alteration were suspected of being present.

- X The skin factor is the measurement of the completion condition of the well. The skin factor is quantified by a positive value indicating a damaged completion and a negative value indicating a stimulated completion.
1. The magnitude of the positive value indicating a damaged completion is dictated by the transmissibility of the formation.
 2. A negative value of -4 to -6 generally indicates a hydraulically fractured completion, whereas a negative value of -1 to -3 is typical of an acid stimulation in a sandstone reservoir.
 3. The skin factor can be used to calculate the effective wellbore radius, r_{wa} also referred to the apparent wellbore radius. (See Appendix, page A-13)
 4. The skin factor can also be used to correct the injection pressure for the effects of wellbore damage to get the actual reservoir pressure from the measured pressure.

- X The skin factor is calculated from the following equation:

$$s = 1.1513 \left[\frac{P_{1hr} - P_{wff}}{m} - \log \left(\frac{k \cdot t_p}{(t_p + 1) \cdot \phi \cdot \mu \cdot c_t \cdot r_w^2} \right) + 3.23 \right]$$

where, s = skin factor, dimensionless

P_{1hr} = pressure intercept along the semilog straight line at a shut-in time of 1 hour, psi

P_{wff} = measured injection pressure prior to shut-in, psi

μ = appropriate viscosity at reservoir conditions, cp (See Appendix, page A-14)

m = slope of the semilog straight line, psi/cycle

k = permeability, md

ϕ = porosity, fraction

c_t = total compressibility, psi^{-1}

r_w = wellbore radius, feet

t_p = injection time, hours

Note that the term $t_p/(t_p + \Delta t)$, where $\Delta t = 1$ hr, appears in the log term. This term is usually assumed to result in a negligible contribution and typically is taken as 1 for large t . However, for relatively short injection periods, as in the case of a drill stem test (DST), this term can be significant.

Radius of Investigation

- X The radius of investigation, r_i , is the distance the pressure transient has moved into a formation following a rate change in a well.
- X There are several equations that exist to calculate the radius of investigation. All the equations are square root equations based on cylindrical geometry, but each has its own coefficient that results in slightly different results, (See Oil and Gas Journal, Van Poolen, 1964).
- X Use of the appropriate time is necessary to obtain a useful value of r_i . For a falloff time shorter than the injection period, use Agarwal equivalent time function, Δt_e , at the end of the falloff as the length of the injection period preceding the shut-in to calculate r_i .
- X The following two equivalent equations for calculating r_i were taken from SPE Monograph 1, (Equation 11.2) and Well Testing by Lee (Equation 1.47), respectively:

$$r_i = \sqrt{0.00105 \frac{k \cdot t}{\phi \cdot \mu \cdot c_t}} \equiv \sqrt{\frac{k \cdot t}{948 \cdot \phi \cdot \mu \cdot c_t}}$$

Effective Wellbore Radius

- X The effective wellbore radius relates the wellbore radius and skin factor to show the effects of skin on wellbore size and consequently, injectivity.
- X The effective wellbore radius is calculated from the following:

$$r_{wa} = r_w e^{-s}$$

- X A negative skin will result in a larger effective wellbore radius and therefore a lower injection pressure.

Reservoir Injection Pressure Corrected for Skin Effects

- X The pressure correction for wellbore skin effects, ΔP_{skin} , is calculated by the following:

$$\Delta P_{skin} = 0.868 \cdot m \cdot s$$

where, m = slope of the semilog straight line, psi/cycle
 s = wellbore skin, dimensionless

- X The adjusted injection pressure, P_{wfa} is calculated by subtracting the ΔP_{skin} from the measured injection pressure prior to shut-in, P_{wf} . This adjusted pressure is the calculated reservoir pressure prior to shutting in the well, $\Delta t=0$, and is determined by the following:

$$P_{wfa} = P_{wf} - \Delta P_{skin}$$

- X From the previous equations, it can be seen that the adjusted bottomhole pressure is directly dependent on a single point, the last injection pressure recorded prior to shut-in. Therefore, an accurate recording of this pressure prior to shut-in is important. Anything that impacts the pressure response, e.g., rate change, near the shut-in of the well should be avoided.

Determination of the Appropriate Fluid Viscosity

- X If the wastestream and formation fluid have similar viscosities, this process is not necessary.
- X This is only needed in cases where the mobility ratios are extreme between the wastestream, $(k/\mu)_w$, and formation fluid, $(k/\mu)_f$. Depending on when the test reaches radial flow, these cases with extreme mobility differences could cause the derivative curve to change and level to another value. Eliminating alternative geologic causes, such as a sealing fault, multiple layers, dual porosity, etc., leads to the interpretation that this change may represent the boundary of the two fluid banks.
- X First assume that the pressure transients were propagating through the formation fluid during the radial flow portion of the test, and then verify if this assumption is correct. This is generally a good strategy except for a few facilities with exceptionally long injection histories, and consequently, large waste plumes. The time for the pressure transient to exit the waste front is calculated. This time is then identified on both the log-log and semilog plots. The radial flow period is then compared to this time.
- X The radial distance to the waste front can then be estimated volumetrically using the following equation:

$$r_{\text{waste plume}} = \sqrt{\frac{0.13368 \cdot V_{\text{waste injected}}}{\pi \cdot h \cdot \phi}}$$

where, $V_{\text{waste injected}}$ = cumulative waste injected into the completed interval, gal

$r_{\text{waste plume}}$ = estimated distance to waste front, ft

h = interval thickness, ft

ϕ = porosity, fraction

X The time necessary for a pressure transient to exit the waste front can be calculated using the following equation:

$$t_w = \frac{126.73 \cdot \mu_w \cdot c_t \cdot V_{\text{waste injected}}}{\pi \cdot k \cdot h}$$

where, t_w = time to exit waste front, hrs

$V_{\text{waste injected}}$ = cumulative waste injected into the completed interval, gal

h = interval thickness, ft

k = permeability, md

μ_w = viscosity of the historic waste plume at reservoir conditions, cp

c_t = total system compressibility, psi^{-1}

X The **time should be plotted on both the log-log and semilog plots** to see if this time corresponds to any changes in the derivative curve or semilog pressure plot. If the time estimated to exit the waste front occurs before the start of radial flow, the assumption that the pressure transients were propagating through the reservoir fluid during the radial flow period was correct. Therefore, the viscosity of the reservoir fluid is the appropriate viscosity to use in analyzing the well test. If not, the viscosity of the historic waste plume should be used in the calculations. If the mobility ratio is extreme between the wastestream and formation fluid, adequate information should be included in the report to verify the appropriate fluid viscosity was utilized in the analysis.

Reservoir Thickness

X The thickness used for determination of the permeability should be justified by the operator. The net thickness of the defined injection interval is not always appropriate.

X The permeability value is necessary for plume modeling, but the transmissibility value, kh/μ , can be used to calculate the pressure buildup in the reservoir without specifying values for each parameter value of k , h , and μ .

X Selecting an interval thickness is dependent on several factors such as whether or not the injection interval is composed of hydraulically isolated units or a single massive unit and wellbore conditions such as the depth to wellbore fill. When hydraulically isolated sands

are present, it may be helpful to define the amount of injection entering each interval by conducting a flow profile survey. Temperature logs can also be reviewed to evaluate the intervals receiving fluid. Cross-sections may provide a quick look at the continuity of the injection interval around the injection well.

- X A copy of a SP/Gamma Ray well log over the injection interval, the depth to any fill, and the log and interpretation of available flow profile surveys run should be submitted with the falloff test to verify the reservoir thickness value assumed for the permeability calculation.

Use of Computer Software

- X To analyze falloff tests, operators are encouraged to use well testing software. Most software has type curve matching capabilities. This feature allows the simulation of the entire falloff test results to the acquired pressure data. This type of analysis is particularly useful in the recognition of boundaries, or unusual reservoir characteristics, such as dual porosity. It should be noted that type curve matching is not considered a substitute, but is a compliment to the analysis.
- X All data should be submitted on a CD-ROM with a label stating the name of the facility, the well number(s), and the date of the test(s). The label or READ.Me file should include the names of all the files contained on the CD, along with any necessary explanations of the information. The parameter units format (hh:mm:ss, hours, etc.) should be noted for the pressure file for synchronization to the submitted injection rate information. The file containing the gauge data analyzed in the report should be identified and consistent with the hard copy data included in the report. If the injection rate information for any well included in the analysis is greater than 10 entries, it should also be included electronically.

Common Sense Check

- X After analyzing any test, always look at the results to see if they “make sense” based on the type of formation tested, known geology, previous test results, etc. Operators are ultimately responsible for conducting an analyzable test and the data submitted to the regulatory agency.
- X If boundary conditions are observed on the test, review cross-sections or structure maps to confirm if the presence of a boundary is feasible. If so, the boundary should be considered in the AOR pressure buildup evaluation for the well.
- X Anomalous data responses may be observed on the falloff test analysis. These data anomalies should be evaluated and explained. The analyst should investigate physical causes in addition to potential reservoir responses. These may include those relating to the well equipment, such as a leaking valve, or a channel, and those relating to the data

acquisition hardware such as a faulty gauge. An anomalous response can often be traced to a brief, but significant rate change in either the test well or an offset well.

- X Anomalous data trends have also been caused by such things as ambient temperature changes in surface gauges or a faulty pressure gauge. Explanations for data trends may be facilitated through an examination of the backup pressure gauge data, or the temperature data. It is often helpful to qualitatively examine the pressure and/or temperature channels from both gauges. The pressure data should overlay during the falloff after being corrected for the difference in gauge depths. On occasion, abrupt temperature changes can be seen to correspond to trends in the pressure data. Although the source of the temperature changes may remain unexplainable, the apparent correlation of the temperature anomaly to the pressure anomaly can be sufficient reason to question the validity of the test and eliminate it from further analysis.

- X The data that is obtained from pressure transient testing should be compared to permit parameters. Test derived transmissibilities and static pressures can confirm compliance with non-endangerment (Area Of Review) conditions.

APPENDIX F

EPA Region 9 Step Rate Test Procedure Guidelines

UIC Permit R9UIC-CA1-FY15-2R

Refer also to:

Society of Petroleum Engineers (SPE) Paper #16798, Systematic Design and Analysis of Step-Rate Tests to Determine Formation Parting Pressure

(This paper can be ordered from the SPE website.)

**UNITED STATES ENVIRONMENTAL PROTECTION AGENCY
REGION IX
DRINKING WATER PROTECTION
75 HAWTHORNE STREET
SAN FRANCISCO, CA 94105**

STEP-RATE TEST PROCEDURE GUIDELINES

PURPOSE:

The purpose of the document is to provide guidelines for performing a Step-Rate Test (SRT). Test results shall be used by the EPA Region 9 (EPA) Underground Injection Control (UIC) offices to determine a Maximum Allowable Injection Pressure (MAIP) at the wellhead that will provide for the protection of underground sources of drinking water (USDW) at injections wells.

A detailed work plan proposal must be submitted to EPA for review and approval prior to the SRT being performed. The work plan must include detailed plans, supporting justifications and associated calculations for conducting the SRT. Refer to the Society of Petroleum Engineers (“SPE”) paper 16798 for supporting test design and analysis guidance (1987, Society of Petroleum Engineers).

Dialogue is expected and encouraged during the actual development of the work plan. EPA will review the work plan proposal and will send written communications either to request clarification or changes to the proposed work, or grant approval of the proposed work. Once the SRT plan is approved, we require at least 30 days’ notice in advance of SRT operations so we may schedule an EPA representative to witness the SRT.

Test results will be used by Region 9’s Underground Injection Control permitting program to determine a Maximum Allowable Injection Pressure (MAIP) which is the surface pressure that correlates to (a) 80 percent of the bottom hole pressure (BHP) that represents the Formation Parting Pressure (FPP) of the permitted injection zone, or, (b) 80 percent of the maximum pressure applied during SRTs in which the FPP was not achieved. This determination serves to provide for the protection of the Underground Sources of Drinking Water (USDWs) as required by the regulations at 40 CFR §§ 146.12(e)(3) (fracture pressure) and 146.14(b)(3) (the anticipated maximum pressure and flow rate at which the permittee will operate).

SRT results must be documented and the test should be witnessed by an EPA inspector who can assist in approving real-time modifications.

RECOMMENDED TEST PROCEDURES:

- 1) The well should be shut in long enough prior to testing such that the BHP approximates static formation pressures.
- 2) It is important to use equipment that will be capable of accurately controlled pumping rates at varying amounts and exceeding the estimated Formation Parting Pressure (FPP) or alternately,

equipment that will exceed the operator's equipment limitations by 120%. Operator must also ensure that sufficient water will be available onsite to complete the SRT. The water used for the SRT may be the operator's permitted wastewater or other water with known specific gravity.

3) Measure and record test pressures with both down-hole and surface pressure recorders. Observe, record, and synchronize surface and BHP pressures, times, dates, and injection rates for each increment (step) of the test. The BHP behavior will be the basis for the determination of FPP. Surface pressures will also be observed to monitor pressure versus rate behavior during the SRT and to determine pressure losses due to friction and other factors that affect the MAIP.

4) The step intervals must be of equal duration and their duration must be of no less than the minimum 30 minutes. Engineering based justification of the planned duration for the steps is required. Steps must be sufficiently long to overcome well bore storage effects and achieve or clearly demonstrate a stabilized pressure (radial flow) at the end of each timed step.

5) The SRT should proceed continuously and uninterrupted, with minimally delayed transition between steps. The SRT must be planned to provide at least 3 to 5 steps before reaching the expected FPP and at least 3 additional steps after exceeding the FPP. Alternatively, the SRT must exceed the BHP that occurs at the operator's maximum equipment surface pressure limitation by at least 120 percent of that corresponding BHP.

6) Because a surface readout of the BHP is employed, the duration of the planned injection rate increments may be modified during the initial part of the test. This will allow, for instance, an initial determination whether modification of the subsequent rate increments may be necessary to obtain at least three BHP data points above the FPP or to adequately exceed the proposed operator's maximum equipment limitation before concluding the test. The well operator shall consult and receive approval from the onsite EPA inspector before any modifications to the plan are implemented during ongoing SRT operations.

7) After pumping stops, observe and record (a) the instantaneous shut-in pressure (ISIP) and (b) the injection zone's pressure fall-off decline for a sufficient time to allow a pressure transient analysis which shall be included in the operator's report. The length of time for pressure fall-off observation will be determined in consultation with EPA prior to conducting the SRT, but may be modified by EPA depending on the actual BHP fall-off behavior observed at the conclusion of the test.

APPENDIX G

Plugging and Abandonment Plans

WD-2 P&A Procedure
WD-3 P&A Procedure

MW P&A Procedure

UIC Permit R9UIC-CA1-FY15-2R

**HILMAR CHEESE COMPANY
MERCED COUNTY, CALIFORNIA**

PROCEDURE TO PLUG AND ABANDON WELL WD-2

(Before & After Well Schematics of WD-2 are provided as Figures Q.2-1 & Q.2-2)

All depths referenced to Driller's KB, 13 feet above ground level

1. Obtain approval from the EPA, Region 9 to plug and abandon Well WD-2.
2. Prepare location for a workover rig and associated equipment.
3. Move in and rig up a workover rig.
4. Pump 80 bbl of 9.0 lb/gal brine (or KCl) water down the 5-inch injection tubing to kill the well.
5. Nipple down the wellhead components above the casing spool. Nipple up a BOP. Function test and pressure test the BOP.
6. Either spear the 5-inch, 18 lb/ft tubing or connect a 5-inch, 18 lb/ft landing joint into the mandrel hanger.
7. Rig up a casing crew for pulling the 5-inch, 18 lb/ft, injection tubing (floating seal assembly inside Liner Packer PBR). Trip out of the hole laying down approximately 3,264 feet of 5-inch tubing.
8. Pick up a 4 ½-inch bit on a 2 ⅞-inch workstring and trip in the well to the top of the wellbore fill. Rig up a power swivel and attempt to wash out the wellbore fill until circulation is lost. Trip out of the hole and lay down bit.
9. Pick up a casing scraper for 7-inch, 23 lb/ft casing and trip in the well to approximately 3,200 feet. Trip out of the hole and lay down the casing scraper.
10. Trip in the hole with a cement retainer and set at approximately 3,190 feet.
11. Pick up a cement stinger for the cement retainer and trip in the hole. Engage the cement stinger in cement retainer and establish a pump-in rate into the injection interval.
12. Rig up a cementing unit and pump 108 sacks (127.5 ft³) of 15.6 lb/gal Class G cement below retainer. Pick up out of cement retainer with the work string and spot approximately 10 sacks (11.8 ft³) of cement above retainer from 3,190 feet to approximately 3,137 feet. Pull the workstring above the cement and reverse out. Trip out of the hole with the workstring and wait on cement.

13. Trip in the hole open-ended with the 2 7/8-inch workstring to the top of the cement at approximately 3,137 feet. Conduct a pressure test on the 7-inch casing to 500 psi for 30 minutes and record the test.
14. Rig up cementing equipment and spot 4, 635-foot balanced plugs from approximately 3,137 feet to 597 using approximately 119 sacks (140.4 ft³) of 15.6 lb/gal Class G cement for each plug. Spot a fifth balanced cement plug from approximately 597 feet to 18 feet using 108 sacks (128 ft³) of 15.6 lb/gal Class G cement.
15. Rig down and move out workover rig and associated equipment.
16. Excavate around well so that all casing strings can be cut-off 5 feet below ground level. Top out with cement, if necessary.
17. Weld a 1/2-inch steel plate over the outer casing string with the following information inscribed on the plate: Operator Name, Well Name, Serial Number and Plugging and Abandonment Date. Backfill the excavation.
18. Prepare a closure report for submittal to EPA, Region 9.

**HILMAR CHEESE COMPANY
MERCED COUNTY, CALIFORNIA**

PROCEDURE TO PLUG AND ABANDON WELL WD-3

(Before & After Well Schematics of WD-3 are provided as Figures Q.3-1 & Q.3-2)

All depths referenced to Driller's KB, 13 feet above ground level

1. Obtain approval from the EPA, Region 9 to plug and abandon Well WD-3.
2. Prepare location for a workover rig and associated equipment.
3. Move in and rig up a workover rig.
4. Pump 80 bbl of 9.0 lb/gal brine (or KCl) water down the 5 ½-inch injection tubing to kill the well.
5. Nipple down the wellhead components above the casing spool. Nipple up a BOP. Function test and pressure test the BOP.
6. Either spear the 5 ½-inch, 17 lb/ft tubing or connect a 5 ½-inch, 18 lb/ft landing joint into the mandrel hanger.
7. Rig up a casing crew for pulling the 5 ½-inch, 17 lb/ft, injection tubing (floating seal assembly inside Liner Packer PBR). Trip out of the hole laying down approximately 3,121 feet of 5-inch tubing.
8. Pick up a 4 ½-inch bit on a 2 ⅞-inch workstring and trip in the well to the top of the wellbore fill. Rig up a power swivel and attempt to wash out the wellbore fill until circulation is lost. Trip out of the hole and lay down bit.
9. Pick up a casing scraper for 7-inch, 23 lb/ft casing and trip in the well to approximately 3,100 feet. Trip out of the hole and lay down the casing scraper.
10. Trip in the hole with a cement retainer and set at approximately 3,080 feet.
11. Pick up a cement stinger for the cement retainer and trip in the hole. Engage the cement stinger in cement retainer and establish a pump-in rate into the injection interval.
12. Rig up a cementing unit and pump 70 sacks (82.6 ft³) of 15.6 lb/gal Class G cement below retainer. Pick up out of cement retainer with the work string and spot approximately 10 sacks (11.8 ft³) of cement above retainer from 3,080 feet to approximately 3,027 feet. Pull the workstring above the cement and reverse out. Trip out of the hole with the workstring and wait on cement.
13. Trip in the hole open-ended with the 2 ⅞-inch workstring to the top of the cement at approximately 3,027 feet. Conduct a pressure test on the 7-inch casing to 500 psi for 30 minutes and record the test.

14. Rig up cementing equipment and spot 4, 635-foot balanced plugs from approximately 3,027 feet to 632 using approximately 119 sacks (140.4 ft³) of 15.6 lb/gal Class G cement for each plug. Spot a fifth balanced cement plug from approximately 540 feet to 18 feet using 98 sacks (115.4 ft³) of 15.6 lb/gal Class G cement.
15. Rig down and move out workover rig and associated equipment.
16. Excavate around well so that all casing strings can be cut-off 5 feet below ground level. Top out with cement, if necessary.
17. Weld a ½-inch steel plate over the outer casing string with the following information inscribed on the plate: Operator Name, Well Name, Serial Number and Plugging and Abandonment Date. Backfill the excavation.
18. Prepare a closure report for submittal to EPA, Region 9.

9 PLUGGING AND ABANDONMENT

9.1 PLUGGING AND ABANDONMENT OF MONITORING WELLS

The cement-filled method will be employed to plug and abandon the monitoring wells. This technique involves displacing the cement through a work string which has been run into the casing. The cement slurry is pumped down the work string and up the annulus to a calculated height which would balance the cement inside and outside the work string. The work string is then slowly pulled out of the cement leaving a solid, uniform plug. After waiting for cement to gain compressive strength, the plug is tagged and then the process repeats itself. The cementing operation will be conducted with approximately three 750-ft plugs to fill the wellbore from the plugged back depth of ~2,200 ft to surface. The plugs will be set at depths consistent with EPA-Region 9 plugging standards to prevent a pathway for upward fluid migration within the AOR.

Finally, after all cement plugs are set, the well casings will be cut off 6-ft below grade and capped by welding a ½ inch steel plate to the outermost casing string.

The plugging and abandonment procedures are described as follows:

- 1 Notify the county, state, and EPA-Region 9 regulatory agencies of the Mechanical Integrity Test (MIT) schedule. Conduct an annulus pressure test. Rig down the wireline unit.
- 2 Prepare the well and location for plugging. Remove the wellhouse (if present), well monitoring equipment, and wellhead injection tubing.
- 3 Move in and rig up a frac tank and fill with 500 bbls mixing water for cement.
- 4 Move in and rig up the workover unit with Blow Out Preventer (BOP) equipment and a 2 7/8-inch work string.
- 5 Remove the wellhead and install the BOP equipment and stripper head.
- 6 Unseat the packer and displace the annular fluid by flushing annulus with 200 bbls of potassium chloride brine.
- 7 Trip out of the hole laying down the 2 7/8-inch injection tubing and packer.
- 8 Rig up the wireline unit and run a casing inspection log and a cement bond/variable density log from total depth to the surface. Pick up and run a wireline set cement retainer to ~2,150 ft (50 ft above top perforation) in the 5 ½-inch protection casing. Rig down the wireline unit.
- 9 Trip in hole to the cement retainer with 2 7/8-inch workstring.
- 10 Rig up cement service equipment. Cement shall be Class "A" (or comparable), weighing 15.6 pounds/gallon. Pressure test the surface lines as required.

- 11 Squeeze cement below cement retainer and into perforations in the USDW. Since cement is below retainer, do not wait on cement to set.
- 12 Using necessary spacer fluids and pre-flushes, spot sufficient Class "A" (or comparable) cement slurry to develop a cumulative 750-ft column (minimum). Pull the tubing up 750 ft and reverse out excess cement. Catch a sample of cement to check curing time and compressive strength. Allow the cement to set overnight (8-hour minimum) before tagging top of plug to confirm proper setup and location. Pressure test the plug to the pressure recommended by the EPA-Region 9. If cement is set adequately, proceed to Step 13. Otherwise, spot additional cement on top of the first plug, as before, to achieve a cumulative 750-ft cement plug. Allow cement to set for a longer period, if necessary.
- 13 Pull tubing up to 1,400 ft. Place Class "A" (or comparable) cement plug from 1,400 ft to 650 ft. Pull the tubing out of the hole. Shut down for 8 hours, or as required; then, tag the plug to confirm location.
- 14 Run in the hole and tag cement. Pull tubing up to 640 ft. Place Class "A" (or comparable) cement plug from 650 ft to surface.
- 15 Cut casing strings ± 6 ft below ground surface.
- 16 Weld a $\frac{1}{2}$ inch steel plate across the 7- inch casing. Inscribe on plate, in a permanent manner, the following information: (1) operator name, (2) closure date, and (3) Underground Injection Control (UIC) permit number.
- 17 Release all equipment and clean up the location.
- 18 Submit closure data to the EPA-Region 9, California Department of Water Resources, and county.

Once closure operations are complete and the well is officially plugged and abandoned, a closure report certifying that the well or wells were closed in accordance with applicable requirements, will be submitted to the proper agencies within 30 days of completed plugging operations. When plugging and abandonment is complete, HCC will submit certification to the EPA-Region 9 and Merced County (by HCC and by a licensed, professional engineer with current registration in California, who is knowledgeable and experienced in practical drilling engineering and who is familiar with the special conditions and requirements of injection well construction) that the injection well has been closed.

9.2 FINANCIAL ASSURANCE OF MONITORING WELLS

Based on the scope in Section 9.2, the cost estimate to plug and abandon each monitoring well is approximately \$152,000 (Appendix E). This cost estimate includes 20% contingency.

APPENDIX H

Monitoring Well Work Plan

UIC Permit R9UIC-CA1-FY15-2R



May 4, 2021

Mr. David Basinger
Groundwater UIC Office
U.S. Environmental Protection Agency, Region 9
75 Hawthorne St. (WTR-4.2)
San Francisco, CA 94105-3901

RE: Hilmar Cheese Company, Inc.
Class I UIC Permit #CA10500001
Monitoring Well Installation Final Work Plan

Dear Mr. Basinger:

HCC is pleased to submit a final work plan to install two monitoring wells within the Area of Review as delineated in the June 2018 Revised Non-Hazardous Permit Renewal Application for a Waste Injection Well.

Any questions or requests for additional information may be addressed to the attention of Julie Connel, Environmental Coordinator, at (209) 656-1171 or jconnel@hilmarcheese.com.

Sincerely,

Michael Wood

Michael Wood
Director, Environmental Safety Health &
Security

Enclosure

cc: California Regional Water Quality Control Board
California Geologic Energy Management Division

Headquarters & Innovation Center

8901 North Lander Avenue, P.O. Box 910, Hilmar, CA 95324 USA T: 209.667.6076 Fax: 209.634.1408 hilmarcheese.com

California Manufacturing Site & Visitor Center: 9001 North Lander Avenue, P.O. Box 910, Hilmar, CA 95324 USA T: 209.667.6076

Texas Manufacturing Site: 12400 US Highway 385, P.O. Box 1300, Dalhart, TX 79022 USA T: 806.244.8800

HILMAR CHEESE COMPANY

MONITORING WELL PLAN

WORK PLAN TO MONITOR CLASS I WELLS AT
HILMAR CHEESE COMPANY, HILMAR,
CALIFORNIA

MAY 4, 2021

REVISION 2 - FINAL





MONITORING WELL PLAN

WORK PLAN TO MONITOR CLASS I WELLS AT HILMAR CHEESE COMPANY, HILMAR, CALIFORNIA

HILMAR CHEESE COMPANY

REVISION 2 - MAY 4, 2021
REVISION 1 - MARCH 19, 2021
ORIGINAL - DECEMBER 31, 2020

PROJECT NO.: 192024F
DATE: MAY 2021

WSP
SUITE 200
16200 PARK ROW
HOUSTON, TX 77084

TEL.: +1 281 589-5900
FAX: +1 281 759-5164
WSP.COM



RESPONSE TO COMMENTS

2.1 CRITICAL PRESSURE RISE AND ZEI	
EPA Comment	Please revise the final sentence in this section to “The monitoring program is designed to collect data that will be included, along with injection well data, in the required annual ZEI recalculation, and for evaluating potential further corrective action to re-enter and plug and abandon the improperly abandoned wellbores within the area of review (AOR).”
HCC Response	The sentence was revised as requested with additional clarifying language.
Document Update	Section 2.1, Page 2-1
2.2 ARTIFICIAL PENETRATIONS WITHIN THE ZEI	
EPA Comment	The conditions listed to determine if an artificial penetration within the ZEI may serve as a conduit for fluid movement are incomplete. Please add one more condition to the list as follows: Lack of a cement plug at the base of USDWs.
HCC Response	The addition was made as requested.
Document Update	Section 2.2, Page 2-2, 3rd Bullet
EPA Comment	The last paragraph on page 2-2 states that HCC will collect data during the drilling and completion of MW-1D and MW-2D to better define the following parameters of the critical pressure and ZEI calculation. Please amend the final bullet of parameters to state that formation pressure will be measured at the top of the Injection Zone.
HCC Response	The addition was made as requested.
Document Update	Section 2.2, Page 2-2, Last bullet
3.1 SURFACE LOCATIONS	
EPA Comment	Please revise to reflect that EPA requested that the two monitoring wells be drilled within 100 feet of the two nearest improperly abandoned wellbores.

HCC Response	The revision was made as requested.
Document Update	Section 3.1, Page 3-1
EPA Comment	Monitoring Well No. 1 should be located within 100 feet of AP-1 rather than the 100-200 feet stated in paragraph #2 on page 3-1 since it will be drilled as a vertical wellbore.
HCC Response	The correction was made as requested. Due to a discrepancy in the historical well records regarding the location of AP-1, a geophysical (magnetometer) survey will be conducted to located the wellbore, and HCC will include specific distances and locations in the drilling plans.
Document Update	Section 3.1, Page 3-1 , Appendix C , Figure 3-2 , Figure 4-2
EPA Comment	The vertical portion of the wellbore at the injection zone and lowermost USDW should be located within 100 feet of AP-3, not within 100 to 200 feet or within 150 feet as described under Section 4.1 Proposed Construction on page 4-1.
HCC Response	The correction was made as requested. In addition, a geophysical (magnetometer) survey of AP-3 will be conducted to confirm the location of the wellbore, and HCC will include specific distances and locations in the drilling plans.
Document Update	Section 3.1, Page 3-1
4.1 PROPOSED CONSTRUCTION	
EPA Comment	As discussed above, the vertical portion of the wellbore at the injection zone and lowermost USDW should be drilled to within 100 feet of the AP-3 well. Please correct this sentence accordingly.
HCC Response	The correction was made as requested. In addition, geophysical (magnetometer) surveys of AP-1 and AP-3 will be conducted to confirm the locations of the wellbores, and HCC will include specific distances and locations in the drilling plans.
Document Update	Section 4.1, Page 4-1
4.5 TESTING AND SAMPLING DURING DRILLING	
EPA Comment	Please identify the formation sampling tool and the alternate sampling method that would be deployed if the proposed formation sampling tool

	is not workable due to soft sediments encountered in the monitoring wells or the deviated wellbore in MW-2D.
HCC Response	The formation sampling tool and alternate tool is described in the text.
Document Update	Section 4.5, Page 4-3
EPA Comment	The samples collected during drilling should be analyzed directly for TDS in addition to the listed specific conductance, pH, specific gravity, and indicator ions. Please revise the plan accordingly.
HCC Response	The plan was revised as requested.
Document Update	Section 4.5, Page 4-3
6.1 SAMPLING SCHEME	
EPA Comment	The samples collected in the injection zone and the USDW should be analyzed directly for TDS, at least initially, in addition to specific conductance, pH, specific gravity, and indicator ions. Please revise the plan accordingly.
HCC Response	The plan was revised as requested.
Document Update	Section 6.1, Page 6-1
6.2.3 METHOD TO ASSESS STABILIZATION OF FIELD PARAMETERS	
EPA Comment	EPA will require a limit of five (5) percent initially until enough data has been collected to ascertain the typical variability for defining stabilization. Please incorporate this into this section.
HCC Response	HCC added language to the section to clarify the stabilization criteria and acceptable variability for each field parameter. Additionally, HCC defined the methods that will be used to calculate wellbore volume and to determine the number of wellbore volumes required to stabilize field parameters.
Document Update	Section 6.2.3, Page 6-2
6.3.1 SAMPLING METHOD/QUALITY CONTROL	
EPA Comment	EPA will require three swabs in terms of borehole volumes swabbed prior to sampling; please revise the phrasing to reflect that.
HCC Response	HCC proposed a method calculating the wellbore volume and the criteria for the number of well volumes that will be swabbed/purged prior to

	sampling in Section 6.2. An addition was made to refer the reader to Section 6.2.
Document Update	Section 6.2, Section 6.3.1, Page 6-3, 4th bullet
7.1 INTERFERENCE TESTING	
EPA Comment	The lack of a pressure response in the monitoring wells during an interference test may not be conclusive of a lack of hydraulic connection with long-term injection in the WD-3 well and may not warrant a re-evaluation of the extent of the ZEI without an evaluation of the longer-term pressure monitoring data. It should be noted that pressure buildup at the APs may occur due to long-term injection in the WD-3 well without detection of a pressure response in the monitoring wells during interference testing, which may be useful to confirm a hydraulic connection but inconclusive if no response is detected at the monitoring wells. Please revise this section to include these considerations.
HCC Response	HCC reworded the last paragraph to acknowledge the that the results of the interference test alone are not conclusive but may indicate whether further evaluation of the ZEI is warranted, potentially including the evaluation of other data to be agreed upon with EPA. The information collected from the interference test, during the construction and sampling of the monitoring wells, and the pressure data from the injection zone and USDW intervals will provide HCC and EPA with an advanced understanding of the effects of injection within the AOR.
Document Update	Section 7.1, Page 7-1, 3rd paragraph
7.2.1 PRECISION/ACCURACY	
EPA Comment	The pressure gauge accuracy of +/- 0.85 psi and resolution of +/- 0.025 psig may be too insensitive to detect small pressure changes at the monitoring wells, based on pressure interference test data collected at the WD-2 well. Pressure changes observed in the WD-2 test were recorded in hundredths of a psi and varied by less than 1.0 psi during the test. Please review the WD-2 pressure interference test data and propose the use of a more sensitive pressure gauge.
HCC Response	The tool precision has been updated based on discussions with product representative.
Document Update	Section 7.2.1, Page 7-2, Appendix E

TABLE OF CONTENTS

1	INTRODUCTION	1-1
1.1	OVERVIEW	1-1
1.2	OBJECTIVE.....	1-1
2	AREA OF REVIEW	2-1
2.1	CRITICAL PRESSURE RISE AND ZEI.....	2-1
2.2	ARTIFICIAL PENETRATIONS WITHIN ZEI	2-2
3	SITING	3-1
3.1	SURFACE LOCATIONS	3-1
3.2	SELECTION OF MONITORING INTERVALS	3-1
3.2.1	Base of USDW	3-2
3.2.2	Injection Zone	3-3
4	CONSTRUCTION AND DRILLING	4-1
4.1	PROPOSED CONSTRUCTION	4-1
4.2	MATERIALS SPECIFICATIONS	4-2
4.3	DRILLING METHODS.....	4-2
4.4	GEOPHYSICAL LOGGING	4-2
4.5	TESTING AND SAMPLING DURING DRILLING.....	4-3
4.6	WELL DEVELOPMENT.....	4-3
5	MECHANICAL INTEGRITY TESTING.....	5-1
5.1	COMPLETION TESTING	5-1
5.2	PERIODIC TESTING.....	5-1
6	FLUID SAMPLING	6-1
6.1	SAMPLING SCHEME.....	6-1
6.2	PURGING.....	6-2
6.2.1	Purging Method/Equipment, and Installation	6-2
6.2.2	Pumping Rates and Volumes	6-2
6.2.3	Method To Assess Stabilization of Field Parameters	6-2
6.3	SAMPLING.....	6-2
6.3.1	Sampling Method/Quality Control	6-2
6.3.2	Sample Handling and Preservation.....	6-3
6.3.3	Sample Documentation	6-3
6.3.4	Laboratory Testing.....	6-4

TABLE OF CONTENTS

7	FORMATION PRESSURE MONITORING..	7-1
7.1	INTERFERENCE TESTING.....	7-1
7.2	PRESSURE MONITORING.....	7-1
7.2.1	Precision/Accuracy.....	7-2
7.2.2	Equipment and Installation	7-2
7.2.3	Data Analysis Methods.....	7-3
7.2.4	Records	7-3
8	REPORTING	8-1
8.1	BASELINE MONITORING AND COMPLETION REPORTS	8-1
8.2	QUARTERLY MONITORING REPORTS	8-1
8.2.1	Injection Zone Monitoring.....	8-1
8.2.2	USDW Monitoring Report	8-2
9	PLUGGING AND ABANDONMENT	9-1
9.1	PLUGGING AND ABANDONMENT OF MONITORING WELLS.....	9-1
9.2	FINANCIAL ASSURANCE OF MONITORING WELLS	9-2

TABLE OF CONTENTS

TABLES

- 2-1 ARTIFICIAL PENETRATIONS WITHIN THE 2.5-MILE AOR
- 3-1 REGULATORY INTERVALS
- 3-2 CALCULATED R_{WA} AND SALINITY VALUES FOR WD-3
- 3-3 SAMPLING/MONITORING INTERVALS OF THE USDW
- 3-4 MONITORING INTERVAL WITHIN THE INJECTION ZONE
- 4-1 MONITORING WELL CASING PROGRAM
- 6-1 SAMPLING PARAMETERS, PRESERVATION, VOLUMES, AND HOLDING TIMES

FIGURES

- 2-1 SITE MAP AND AREA OF REVIEW
- 3-1 MW-1D SITE LOCATION MAP
- 3-2 MW-2D SITE LOCATION MAP
- 3-3 CROSS-SECTION LINES LOCATION MAP
- 3-4 NORTHWEST-SOUTHEAST GEOLOGIC CROSS-SECTION (A-A')
- 3-5 NORTHEAST-SOUTHWEST GEOLOGIC CROSS-SECTION (B-B')
- 4-1 MW-1D PROPOSED WELLBORE SCHEMATIC
- 4-2 MW-2D PROPOSED WELLBORE SCHEMATIC
- 4-3 GENERIC RETRIEVABLE PACKER WITH SEAL ASSEMBLY
- 4-4 WELLHEAD AND CASING HEAD SCHEMATICS

APPENDICES

- A AREA OF REVIEW METHODS FROM WD-3 PERMIT APPLICATION
- B MW-1D DRILLING PLAN
- C MW-2D DRILLING PLAN
- D DOWNHOLE GAUGE DATA SHEET AND DEPLOYMENT
- E COST ESTIMATE TO PLUG AND ABANDON

1 INTRODUCTION

1.1 OVERVIEW

Hilmar Cheese Company (HCC) is a privately-owned cheese plant at 9001 Lander Ave. in Hilmar, Merced County, California. HCC currently owns and operates one Class I nonhazardous injection well, WD-3, at their HCC Facility. WD-3 is used for injection of brine wastewater from the water reclamation plant. A second Class I nonhazardous injection well, WD-2, is currently inactive and a third Class I injection well, WD-1P, was plugged and abandoned on November 22, 2015.

In June 2018, HCC submitted a permit renewal application to the Environmental Protection Agency – Region 9 (EPA-Region 9) for continued use of the Class I Injection wells at their facility. In response, EPA-Region 9 has requested that HCC submit a monitoring well plan to monitor the Injection Zone near artificial penetrations (APs) adjacent to WD-3 and evaluate the potential for vertical migration from the Injection Zone to the base of the Underground Source of Drinking Water (USDW).

1.2 OBJECTIVE

In compliance with a request from EPA-Region 9, HCC proposes to install two monitoring wells, MW-1D and MW-2D, with the objectives to:

- 1 Determine if injection into the WD-3 Injection Zone is in hydraulic communication with the USDW; and
- 2 Determine if the injection by Hilmar is resulting in a pressure increase in the injection formation.

The information gathered during the installation and monitoring of the monitoring wells will allow HCC to:

- 1 Confirm the depth of the base of the USDW at nearby APs;
- 2 Better characterize the extent of the Zone of Endangering Influence (ZEI) in the Injection Zone; and
- 3 Demonstrate that fluid injected into WD-3 does not cause a sufficient pressure change in adjacent APs to cause fluid to migrate vertically to the USDW.

HCC proposes to collect the following data from the monitoring wells to determine if fluid is vertically migrating from the Injection Zone due to increased pressure gradients:

- Quality of the water from the monitoring intervals;
- Reservoir pressure at the top of the injection formation; and
- Reservoir pressure in the first porous, permeable interval at the base of the USDW.

2 AREA OF REVIEW

According to CFR 146.6, the Area of Review (AOR) for injection wells will be determined by either:

- Zone of endangering influence; or
- Fixed radius around the well of not less than one-fourth (1/4) mile.

In the case of Class I nonhazardous wells, CFR 146.12(a) states:

All Class I wells shall be sited in such a fashion that they inject into a formation which is beneath the lowermost formation containing, within one-quarter (1/4) mile of the well bore, an underground source of drinking water.

At the request of EPA-Region 9, HCC has established the AOR of the active waste disposal well, WD-3, based on the Zone of Endangering Influence (ZEI) radius instead of the defined fixed radius. Per CFR 146.6(a), the ZEI is defined as:

...that area the radius of which is the lateral distance in which the pressures in the Injection Zone may cause the migration of the injection and/or formation fluid into an underground source of drinking water.

2.1 CRITICAL PRESSURE RISE AND ZEI

The critical pressure rise calculation represents the static fluid pressure difference between the Injection Zone and the base of USDW. Any pressure exerted in the Injection Zone, greater than the critical pressure, could cause vertical fluid migration to the base of the USDW in an offset AP that is not properly completed or plugged. In the Permit Application for WD-3, HCC deferred to a critical pressure rise calculated by the EPA-Region 9 (Appendix A). EPA-Region 9 calculated a critical pressure rise 6.77 psi above the normal hydrostatic gradient.

As stated in the section above, the ZEI defines a lateral distance from the injection well where reservoir pressure differential is equal to the critical pressure rise. Based on the EPA-Region 9's calculations, the ZEI exists at an approximate radius of 2.5 miles from WD-3. This means that any increase in formation pressure greater than 6.77 psi above the normal hydrostatic gradient may cause fluid to migrate vertically along an inadequately plugged AP within the ZEI. The monitoring program is designed to collect data that will be included, along with injection well data, in the required annual ZEI recalculation. Additionally, the monitoring program has been specifically designed to evaluate the potential for vertical migration from the injection zone into the USDW, in lieu of re-entering and plugging abandoned bore holes. It is understood that any

evaluation of the ZEI will be based on a data set considerate of all testing conducted, including data collected over the long-term injection of waste. This comprehensive data set will be evaluated to determine appropriate corrective actions that, if required, may include re-entering and plugging improperly abandoned well bores within the area of review (AOR).

2.2 ARTIFICIAL PENETRATIONS WITHIN ZEI

Eight APs have been identified within the assumed 2.5-mile ZEI and are listed in Table 2-1 and depicted on Figure 2-1. The following conditions are used to determine if an artificial penetration within the ZEI may serve as a conduit for fluid movement:

- The wellbore penetrates the confining zone or Injection Zone/Injection Interval; and
- The surface casing is not set and cemented below the base of the USDW; or
- A cement plug is not set at the base of the USDW; The production casing that penetrates the Injection Zone does not have a calculated top of cement between the base of the USDW and the top of the Injection Zone;
- A cement plug is not set inside of casing between the base of the USDW and the Injection Zone; and/or
- An open-hole cement plug is not set between the base of the USDW and the Injection Zone.

Some regulatory agencies have found that relatively dense drilling mud used to plug an openhole completion can provide a sufficient barrier to fluid migration. However, EPA-Region 9 has found that mud can degrade over time under some circumstances, and therefore assumes that APs plugged with mud can serve as conduits for fluid migration.

Table 2-1 provides a summary of the casing, cementing and plugging data for each AP in the ZEI, along with an evaluation of their casing and plugging programs. It was determined that the wells in the ZEI were constructed and plugged in a manner that may provide a conduit for fluid migration under the criteria applied by EPA Region 9. However, HCC plans to collect data to verify whether APs, not plugged to current EPA standards, experience a change in pressure to induce fluid movement along their wellbore.

HCC will collect data during the drilling and completion of MW-1D and MW-2D to better define the following parameters of the critical pressure and ZEI calculation:

- Depth to the base of the USDW;
- Static water level of the USDW formation (once the wells are plugged back to USDW monitoring interval);
- Formation pressure at the base of the USDW;
- Depth of the top of the Injection Zone;

- Formation characteristics of the Confining and Injection Zones; and
- Formation pressure at the top of the Injection Zone.

Once these parameters are verified, HCC is confident that these calculations, along with pressure monitoring of the injection zone and base of the USDW, will show that fluid injected into WD-3 is confined within the approved Injection Zone.

3 SITING

3.1 SURFACE LOCATIONS

The EPA-Region 9 requested that HCC drill monitoring wells within 100 feet (ft) of two of the nearest APs. HCC contacted the land/mineral owners adjacent to APs 1, 2, and 3, and was able to secure access to properties near AP-1 and AP-3 to install monitoring wells (See Figure 2-1). Prior to drilling the proposed monitoring wells, HCC will confirm the locations of AP-1 and AP-3 in the field by conducting a geophysical survey, using a magnetometer. If the historic locations of the wells cannot be confirmed or if the locations vary significantly, HCC will consult with EPA to address any significant changes to the proposed siting of the monitoring wells.

Monitoring Well No. 1 (MW-1D) will be sited approximately 4,400 ft southeast of WD-3 and approximately 100 ft southwest of AP-1. Access to a 150 x 250-ft parcel of land located adjacent to the target AP has been secured to drill MW-1D (Figure 3-1). The property is located in the northwest quarter of Section 14, Township 6 South, Range 10 East (Figure 2-1). Changes to the location of MW-1D or its proximity to AP-1 will be presented in the drilling plans.

Monitoring Well No. 2 (MW-2D) will be sited approximately 3,900 ft northwest of WD-3 and approximately 500 ft southeast of AP-3. Since HCC was not able to access property within 100 ft of AP-3, HCC will drill MW-2D as a deviated well where the portion of the wellbore from the lowermost USDW to the injection zone is 100 feet from the surface location of AP-3. HCC was able to secure a 200 x 200-ft parcel of land to drill the surface location of MW-2D (Figure 3-2). The property is located in the northwest quarter of Section 10, Township 6 South, Range 10 East (Figure 2-1). If there are any changes to the location of MW-2D or its proximity to AP-3, it will be presented in the drilling plans.

3.2 SELECTION OF MONITORING INTERVALS

HCC will assess whether fluid injected into WD-3 is confined within the approved Injection Zone, and that fluid will not vertically migrate from the approved Injection Zone to the USDW. The regulatory zones defined for WD-3 were correlated to the electric logs of APs 1 and 3, and the depths (referenced from the rig kelly bushing [KB]) are provided on Table 3-1.

Table 3-1 Regulatory Intervals

REGULATORY INTERVALS	WD-3 ¹ (Waste Disposal Well) Depth (FT-KB)	AP - 1 ² C.F. Braun & Co, C.B. Young No. 1 (To be monitored by MW-1D) Depth (FT-KB)	AP - 3 ³ Atlantic Oil Co, Hilmar No. 1 (To be monitored by MW-2D) Depth (FT-KB)
Base of the USDW (Permit)	2,110	2,130	2,140
Upper Confining Zone	3,170-3,248	3,250-3,401	3,173-3,285
Injection Zone	3,248-3,928	3,401-4,108	3,285-4,018
Lower Confining Zone	3928-4,040	4,108-4,210	4,012-4,100

¹ WD No. 3 - KB: 114 FT Above Mean Sea Level (AMSL), Ground Level (GL): 100.5 FT AMSL

² AP-1 - KB: 102 FT AMSL, GL: 89 FT AMSL

³ AP-3 - KB: 110 FT AMSL, GL: 97.5 FT AMSL

3.2.1 BASE OF USDW

In order to establish the appropriate monitoring interval for the base of the USDW, HCC will confirm the lowermost depth that meets the criteria of USDW near the AP-1 and AP-3. Per CFR 144.6, the USDW is defined as an aquifer or its portion:

- Which supplies any public water system; or
- Which contains a sufficient quantity of groundwater to supply a public water system; and
 - Currently supplies drinking water for human consumption; or
 - Contains fewer than 10,000 mg/l of total dissolved solids (TDS); and
- Which is not an exempted aquifer.

During the permitting of WD-3, the apparent water resistivity (R_{wa}) and corresponding salinity values were calculated from the resistivity log for WD-3 (Table 3-2). Based on the information presented in Table 3-2, the permit application chose a conservative depth of 2,100 ft below KB as the base of the USDW. HCC intends to verify the depth of the USDW by collecting formation fluid samples from the monitoring wells and comparing the TDS against the regulatory standard. HCC wants to ensure that the proper depth is monitored for any unusual changes in pressure. Additionally, the USDW depth and the static water level of the formation where the USDW is found are crucial parameters in the critical pressure calculation.

HCC will vertically profile the interval between approximately 1,750-2,150 ft below KB to identify the base of the USDW near the APs. HCC used the apparent water resistivity (R_{wa}) and corresponding salinity values presented in Table 3-2 as a guide in establishing three USDW sampling intervals.

- Interval 1 corresponds to a sand interval immediately below the last reading to remain below 10,000 ppm.
- Interval 2 corresponds to the reading at 1,986 ft below KB, where the salinity remained above 10,000 ppm.

- Interval 3 corresponds with the depth where the USDW was referenced in the permit application (2,100 ft).

The depths of the sampling intervals as they correlate to WD-3, AP-1, and AP-3 are identified in Table 3-2 and are correlated along cross-section lines within the AOR (Figure 3-3) on the Northwest-Southeast and Northeast-Southwest Cross-Sections, Figure 3-4 and 3-5, respectively.

Table 3-3 Proposed Sampling/Monitoring Intervals of the USDW

USDW SAMPLING/ MONITORING INTERVAL	WD-3 ¹ (Waste Disposal Well)	AP-1 ² C.F. Braun & Co, C.B. Young No. 1 (To be monitored by MW-1D)	AP-3 ³ Atlantic Oil Co, Hilmar No. 1 (To be monitored by MW-2D)
	Depth (FT-KB)	Depth (FT-KB)	Depth (FT-KB)
Interval 1	1,775-1,805	1,810-1,845	1,795-1,850
Interval 2	1,955-2,000	1,930-1,965	1,990-2,030
Interval 3	2,070-2,130	2,040-2,120	2,075-2,135

¹ WD No. 3 - KB: 114 FT Above Mean Sea Level (AMSL), Ground Level (GL): 100.5 FT AMSL

² AP-1 - KB: 102 FT AMSL, GL: 89 FT AMSL

³ AP-3 - KB: 110 FT AMSL, GL: 97.5 FT AMSL

During the drilling and construction of MW-1D and MW-2D, the wells will be logged, and the sampling intervals will be correlated to the corresponding intervals identified in AP-1 and AP-3, respectively. One of the intervals listed in Table 3-3, or its equivalent, will be selected for future USDW monitoring.

3.2.2 INJECTION ZONE

HCC proposes to monitor the uppermost permeable interval within the Injection Zone. The monitoring interval within the zone was identified on the electric logs of AP-1 and AP-3, and the depths are listed in Table 3-4. This interval was correlated along cross-section lines within the AOR (Figure 3-3) and depicted on the Northwest-Southeast (A-A') and Northeast-Southwest (B-B') Cross-Sections, Figure 3-4 and 3-5, respectively.

The Injection Zone in AP-1 is identified from 3,401-4,108 ft below KB, and the target monitoring interval is the top 59 ft of the zone, from 3,401-3,460 ft below KB. The Injection Zone in AP-3 is identified from 3,285-4,018 ft below KB, and the target monitoring interval is the top 65 ft of the zone, from 3,285-3,350 ft below KB (Table 3-4).

Table 3-4 Target Monitoring Interval Within the Injection Zone

MONITORING INTERVAL	WD-3 ¹ (Waste Disposal Well)	AP - 1 ² C.F. Braun & Co, C.B. Young No. 1 (To be monitored by MW-1D)	AP - 3 ³ Atlantic Oil Co, Hilmar No. 1 (To be monitored by MW-2D)
	Depth (FT-KB)	Depth (FT-KB)	Depth (FT-KB)
Within Injection Zone	3,248-3,308	3,401-3,460	3,285-3,350

¹ WD No. 3 - KB: 114 FT Above Mean Sea Level (AMSL), Ground Level (GL): 100.5 FT AMSL

² AP-1 - KB: 102 FT AMSL, GL: 89 FT AMSL

³ AP-3 - KB: 110 FT AMSL, GL: 97.5 FT AMSL

The Injection Zone in the vicinity of the HCC site is in the undifferentiated Paleocene-Cretaceous sands, which are part of a deeper, confined saline aquifer system. The upper sands within the Injection Zone commonly contain chlorite and traces of volcanic fragments. The sands are interpreted to be marine deposits from an inner-shelf sand environment.

Analyses of the cores collected from the Injection Zone of WD-3 reported a porosity range from 30.7% to 38.4% and an average permeability value of 753 millidarcies (md). The lithology of this interval was identified as massive to poorly bedded very fine-grained sands with thin layers of dark mica.

During the drilling and construction of the monitoring wells, MW-1D and MW-2D will be logged and the monitoring intervals will be correlated to the corresponding intervals identified in AP-1 and AP-3, respectively.

4 CONSTRUCTION AND DRILLING

4.1 PROPOSED CONSTRUCTION

The drilling plans for both MW-1D and MW-2D are included as Appendix B and Appendix C, respectively. The well schematics for MW-1D and MW-2D are included as Figure 4-1 and Figure 4-2, respectively.

The casing program for each monitoring well is as follows:

Table 4-1 Monitoring Well Casing Program

WELLBORE	MW-1D DEPTH FT BGS ¹	MW-2D DEPTH FT BGS	DESCRIPTION
Conductor Casing	0 to ±80	0 to ±80	16-inches conductor casing, wall of 0.656 inch augured or driven to refusal (±80 ft)
Surface Casing	0 to 1,200	0 to 1,200	8 5/8-inch, 24 lb/ft, J-55, ST&C, ID of 8.097 inches
Protection Casing	0 to 3,550	0 to 3,550	5 1/2-inch, 17 lb/ft, J-55, LT&C, ID of 4.892 inches
Injection Tubing	0 to 3,350	0 to 3,250	2 7/8-inch, 6.5 lb/ft, L-80, LT&C, ID of 2.323 inches
Packer	3,350	3,250	5 1/2-inch x 2 7/8-inch packer and seal assembly

¹BGS: Below Ground Surface

As defined in Table 3-4, the completion interval for MW-1D is estimated to be from 3,401 to 3,460 ft KB (~3,388 to 3,447 ft bgs). The completion interval for MW-2D is estimated to be from 3,285 ft to 3,350 ft KB (~3,273 to 3,338 ft bgs).

MW-2D will be drilled as a slightly deviated well such that the USDW and Injection Interval bottomhole locations are within 100 feet of AP-3. As such, the casing setting depths for the 5 1/2-inch protection casing will differ slightly from what is listed in the table above. The exact amount of deviation in the MW-2D wellbore will be determined at a later date. The type and amount of cement calculated for each casing string will be calculated using the casing cement volumes from the calipered borehole volume log, with an added 20-50% excess. The cement will consist of light-weight cement followed by a final slurry of standard, premium cement. The approximate volumes and type of cement will be confirmed in the official drilling program prior to installation of the monitoring wells. The objective is to have cement to surface. A temperature

survey will be run to confirm the top of cement and a cement top out job will be conducted if necessary.

4.2 MATERIALS SPECIFICATIONS

The following carbon steel tubulars will be installed in each monitoring well:

- 16-inch, 0.656-inch wall conductor casing
- 8 $\frac{5}{8}$ -inch surface casing
- 5 $\frac{1}{2}$ -inch protection casing
- 2 $\frac{7}{8}$ -inch injection tubing
- 5 $\frac{1}{2}$ -inch x 2 $\frac{7}{8}$ -inch retrievable packer with seal assembly (details in Figure 4-3)

The wellhead is also constructed of carbon steel material and will have the following dimensions from ground surface:

- 11-inch 3M X 8 $\frac{5}{8}$ -inch Slip on Weld (SOW) Casing head
- 11-inch 3M X 3 $\frac{1}{8}$ -inch Wellhead
- 3 $\frac{1}{8}$ -inch 3M tree assembly with 3 $\frac{1}{8}$ -inch 3M wing valve and 3 $\frac{1}{8}$ -inch 3M crown valve

A detailed description can be found in the wellhead and casing head schematic, Figure 4-4.

4.3 DRILLING METHODS

A rotary drilling rig will be utilized to install the well. A water-based mud fluid system will be used to minimize damage to formation and increase likelihood of obtaining representative fluid samples from the USDW and Injection Intervals while drilling.

4.4 GEOPHYSICAL LOGGING

During drilling, the following downhole geophysical logging will be performed: triple combo logs which include SP, gamma ray, bulk density and neutron porosity. The anticipated logging plan is included in the drilling plans for each well, which are included in Appendices B and C.

After the open hole logs are run in MW-1D and MW-2D, the USDW sampling intervals and the Injection Zone monitoring interval will be identified by correlating them to the depths described

in Table 3-3 and 3-4, respectively. The open hole logs will be used to confirm the fluid sampling and pressure measurements depths.

4.5 TESTING AND SAMPLING DURING DRILLING

As MW-1D and MW-2D are drilled, a Haliburton IDS Fluid Identification and Sampling formation sampling tool (or equivalent) will be used to collect fluid samples and to measure formation pressure and permeability at each discrete sampling interval. If the presence of soft sediments in MW-1D and MW-2D, or the deviated wellbore in MW-2D, are judged by the sampling contractor to present a significant risk of getting sampling equipment stuck in the hole, an alternate sampling method will be proposed. The alternate sampling tool will be the Schlumberger, Cased Hole Dynamics Tester (CHDT) (or equivalent), which can obtain formation water samples in cased holes.

The samples collected during drilling will be analyzed for specific gravity, TDS, specific conductance, pH, and indicator ions (K, Na, Ca, Mg, Cl, and SO₄). If necessary, sidewall cores may be taken within the Confining and Injection Zone and will be submitted to a laboratory to determine the grain density, porosity, and permeability of the formations. Additional sampling and testing details are included in Appendices B and C.

Based on the results of the fluid samples collected from the USDW sampling intervals, the base of the USDW will be identified and one of the proposed intervals will be selected for future monitoring. The samples collected during drilling will serve as the baseline samples for the USDW and Injection Zone monitoring intervals. Baseline sampling of the monitoring intervals will be conducted according to the sampling protocol described in Section 6.

4.6 WELL DEVELOPMENT

The objective of well development is to produce a well capable of yielding fluid samples of acceptable quality. The monitoring wells will be developed using swabbing operations, but if this does not yield sufficient formation fluid, then the wells may need to be jetted with coil tubing.

During swabbing operations, circulated fluid from the formation will be recovered and water quality measurements will be collected in the field. Well development will continue until field measurements reach the desired level or stabilizes. After development is complete, the monitoring wells will be allowed to stabilize and re-equilibrate. The time necessary for stabilization depends on the permeability of the formation.

When the monitoring wells are recompleted at the base of the USDW, the wells will be redeveloped in the new monitoring interval. The well will be developed at the USDW monitoring interval in the same manner as described above. After the formation has stabilized, a static fluid level will be collected prior to sampling the USDW monitoring interval.

5 MECHANICAL INTEGRITY TESTING

5.1 COMPLETION TESTING

An annulus pressure test, cement bond log, and temperature profile will be conducted on the casing-tubing annulus. As discussed in Section 8, a pressure falloff and interference test with WD-3 will be conducted.

5.2 PERIODIC TESTING

An annulus pressure test will be conducted every five years.

6 FLUID SAMPLING

6.1 SAMPLING SCHEME

INITIAL/BASELINE SAMPLING

Initial fluid samples will be collected from the USDW and Injection Zone monitoring intervals using a formation sampling tool during drilling, before the protection casing is installed (Section 4). The samples will be analyzed for specific gravity, TDS, specific conductance, pH, and indicator ions (K, Na, Ca, Mg, Cl, and SO₄). The samples will be handled, preserved, documented, and submitted to a laboratory according to the protocol described in Section 6.3. The analytical results will establish the baseline for each monitoring interval.

INJECTION ZONE INTERVAL SAMPLING

Upon completion of the wells, the Injection Zone monitoring interval will be sampled monthly for 9 months, or until a statistically adequate dataset is generated. Samples will be collected after the monitoring interval has been swabbed to provide representative formation fluid, and when field indicators such as conductivity and pH have stabilized. The samples will be analyzed for specific gravity, TDS, specific conductance, pH, and indicator ions (K, Na, Ca, Mg, Cl, and SO₄). After 9 months of sampling (or a statistically adequate dataset is generated), the monitoring schedule of the Injection Zone will be re-evaluated in consultation with EPA-Region 9. At an agreed upon time, the Injection Zone monitoring interval will be plugged back, and the monitoring wells will be recompleted in the USDW monitoring interval.

USDW INTERVAL SAMPLING

Once the monitoring wells are plugged back and recompleted at the base of the USDW, formation fluid samples will be collected from the USDW monitoring interval. Samples will be collected monthly for 9 months. After a statistically adequate dataset is generated, the sampling frequency will be decreased to quarterly. Samples will be collected after the monitoring interval has been swabbed to provide representative formation fluid, and when field indicators such as conductivity and pH have stabilized. The samples will be analyzed for specific gravity, TDS, specific conductance, pH, and indicator ions (K, Na, Ca, Mg, Cl, and SO₄). After two years, HCC will re-evaluate the sampling frequency in consultation with EPA-Region 9.

6.2 PURGING

6.2.1 PURGING METHOD/EQUIPMENT, AND INSTALLATION

Purging of the monitoring intervals will be conducted to mitigate the impacts of installation and to collect representative fluid samples. Purging will be performed with equipment that is constructed with materials that are chemically inert and will not impact the integrity of the recovered fluid samples.

6.2.2 PUMPING RATES AND VOLUMES

Based on the results of the specific capacity determination, pumping operations will be controlled so that residual drawdown is minimal. However, it is recognized that the amount of residual drawdown could be lower in higher transmissivity formations. Pumped water will be properly contained pending proper disposal.

6.2.3 METHOD TO ASSESS STABILIZATION OF FIELD PARAMETERS

HCC will purge the monitoring intervals three well volumes, while monitoring the stabilization of field-measured water-quality parameters prior to sampling. The recovered water can be considered representative when field parameter values stabilize, i.e. when consecutive field values differ by no more than 5 percent for three parameters between several discrete and independent samples.

A well volume is defined as the volume of water contained in the wellbore at static conditions. For an open hole completion, the well volume is calculated using the diameter of the borehole and the water column from the top of the open hole completion to the depth of the static water level. When the monitoring tubing and packer are installed, the well volume will be the casing volume from the top of the open hole completion to the injection packer plus the capacity of the monitoring tubing.

6.3 SAMPLING

6.3.1 SAMPLING METHOD/QUALITY CONTROL

The sampling methodology was designed to sample and monitor intervals at considerable depth. HCC will implement the following quality control measures to demonstrate the accuracy and precision of the sampling and monitoring program:

- Chemical parameters monitored in ground water at the site will not be adversely affected through chemical transformations resulting from the sample collection method or from exposure to equipment components.
- Sampling devices will be constructed with non-reactive materials and will be thoroughly cleaned before each sampling event.
- The accuracy of the field parameter measurements will be confirmed by calibrating all equipment before each sampling event according to manufacturer's specifications.
- Each monitoring interval will be sufficiently developed and purged (as described in Section 6.2) prior to sampling.
- If a pump is required, it will be turned on and operated at a rate that does not cause significant drawdown of the water column, as measured using a water level sounder.
- During sampling, sufficient water will be collected to supply enough volume for the analytes of concern.
- Samples are properly handled, preserved, and documented according to Section 6.3.2 and 6.3.3.
- At least one replicated sample will be collected and analyzed for each sampling event and will be taken according to the quality assurance procedures for the laboratory.

6.3.2 SAMPLE HANDLING AND PRESERVATION

Aspects of the sampling procedures are designed to ensure that chemistry results obtained for the recovered sample are not severely affected by error. After sample collection, samples requiring preservation will be preserved as soon as practical. The correct preservative for the analytes of interest will be used. The preservation, volumes, and holding times for the proposed sampling parameters (indicator ions) are provided in Table 6-1.

6.3.3 SAMPLE DOCUMENTATION

Sampling documentation will include a sample container labeling, sample seals, a detailed field logbook, and chain- of-custody records.

Samples will be labeled with the well name and depth of sampling interval (i.e. MW-1D-3350). The samples will be custody sealed during storage or shipment. Samples requiring reduced temperature storage will be placed on ice immediately.

A field logbook will be used to record information about each sample during collection, and will include the following:

- Identification of the subject well(s) and calibration data for instrumentation, for water levels or formation pressure;
- Well swabbing procedures/equipment and sample collection procedures/equipment;
- Date and time of sample collection, types of containers, preservatives, and chemical parameters of analysis; and
- Physical and chemical measurements collected in the field that document that stabilized parameters were obtained as well as other field observations that were made.

The chain-of-custody record will include the documentation necessary to trace sample possession from the time of collection to analysis, and must include the following information:

- Identification of the sample, the signature of collector, and the date and time of collection; and
- The signature(s) of person(s) involved in the chain-of-custody, and the inclusive dates of possession.

The field logbook and chain of custody will serve as the official documentation for each sample. These sheets will include at a minimum: the name of the person receiving the sample(s), the laboratory sample number (if different from the field number), the date of sample receipt, and the analyses to be performed.

6.3.4 LABORATORY TESTING

After the samples are properly collected, preserved, and documented, they will be submitted to a California accredited laboratory. The laboratory will analyze each parameter using the EPA approved analytical method defined in Table 6-1.

7 FORMATION PRESSURE MONITORING

Formation pressure monitoring will be conducted by:

- 1 Performing an interference test to establish a baseline event in each monitoring well;
 - 2 Collecting pressure data from the Injection Zone for 9 months, or until a sufficient statistical dataset is established and potential injection effects are assessed; and
 - 3 Collecting pressure data from the USDW until no longer required.
-

7.1 INTERFERENCE TESTING

Interference testing will be conducted as a unique baseline event for each monitoring well in the Injection Zone and base of the USDW.

Based on existing data and the proposed distance of the monitoring wells from the injection well, the relatively low injection rate may not produce a measurable or significant response. Initial predictive modeling of interference testing indicates that it may take 2-4 weeks of injection and 2-4 weeks of well shut-in for a pressure response from WD-3 to be measured in the monitoring wells. Fluid availability will also factor into the duration of the interference test.

HCC is evaluating additional testing methods that may allow for a less than 2 weeks shut-in duration. The methods and data objectives for the interference tests will be further discussed with EPA-Region 9 prior to incorporating them into the permit. HCC wants to ensure that the interference test will provide meaningful data while maintaining facility operations.

A lack of pressure response in the monitoring wells during the interference test is not conclusive on its own that there is no hydraulic connection between the monitoring well and the injection well. HCC plans to use the data collected during the construction and sampling of the monitoring wells, along with the continuous pressure data collected from the monitoring intervals and other potential data to be collected in consultation with the EPA, to improve the accuracy of the ZEI calculation and establish a pressure response to the long-term injection within the AOR.

7.2 PRESSURE MONITORING

To accurately monitor formation pressure within the monitoring intervals, continuous pressure monitoring will be conducted using a downhole gauge installed in the casing-tubing annulus at

the desired datum depth. Formation pressure measurements will be collected weekly or at a frequency that will allow HCC to establish a trend in the data.

The formation pressure monitoring will begin in the Injection Zone monitoring interval at a depth to be determined (target interval depths in Table 3-4). When pressure testing of the Injection Zone monitoring interval is complete, the monitoring wells will be plugged back such that the USDW formation pressure will be monitored (one of the proposed interval depths in Table 3-3).

7.2.1 PRECISION/ACCURACY

The downhole pressure gauge utilizes digital quartz to obtain pressure data. The gauge will be calibrated and tested to full temperature and pressure ratings. The accuracy ranges for pressure and temperature are as follows:

— Pressure

- Total System Pressure Accuracy: $\pm 0.025\%$ of full scale
- Pressure Resolution: ± 0.01 psi (pounds per square inch) or better
- Operating and Calibrated Pressure Ranges: 300 – 5,000 psia (pounds per square inch absolute)

— Temperature

- Accuracy: $\pm 0.9^\circ\text{F}$ (degrees Fahrenheit)
- Resolution: 0.01°F
- Standard Calibration 77°F to 257°F
- Operating Range: -4°F to 392°F
- Typical Reliability Testing Levels -4°F test to confirm fully and correct operation.

The digital quartz downhole pressure gauge calibrated to 5,000 psia will provide total system accuracy of 0.025%, but with an improved resolution of 0.01 psi or better, which will aid in the interpretation of the pressure data gathered from the pressure interference test and other pressure tests conducted.

7.2.2 EQUIPMENT AND INSTALLATION

The downhole gauge will be installed by adding a ported sub to the desired depth on the tubing string. The gauge will be hung off outside the tubing at the datum depth. A communication line from the gauge to the wellhead will be in the casing-tubing annulus and will run through a ported casing head on the wellhead. This communication line will tie into a control panel system next to the wellhead which will continuously record data from the downhole gauge. A power

source will be installed next to the control panel. The data from the control panel will be transmitted electronically to HCC. Periodic maintenance will be conducted on surface equipment for the downhole gauge. Appendix D provides the equipment specifications for the proposed permanent downhole pressure gauge.

7.2.3 DATA ANALYSIS METHODS

The bottom-hole pressure measurements from the bottom-hole pressure gauge will be reviewed for any changes in measurements each week and placed on a graph to observe any change to the pressure trend. The pressure derivative will also be plotted on the graph to observe any changes to the pressure trend.

7.2.4 RECORDS

HCC will obtain an accurate record of formation pressure that will provide raw data and corrected measurements.

HCC will maintain records formation pressure measurements at the site along with documentation on the calibration of the measuring devices. These monitoring data will be accessible to the EPA-Region 9 during site inspections.

8 REPORTING

8.1 BASELINE MONITORING AND COMPLETION REPORTS

A monitoring well completion report for each well will be prepared and submitted to EPA-Region 9 within 45 days of receipt of valid field and laboratory data. Each report will include, at a minimum, the following elements:

- The drilling and complete testing program and accurate record of the depth, thickness, and character of the strata penetrated;
- Casing and cementing records;
- All available logs (mud log sampling records and electric logs) and testing program data on the well and a descriptive report interpreting the results of all logs and tests;
- Measured bottom-hole temperature and pressure;
- A demonstration of mechanical integrity;
- Formation fluid sample laboratory results;
- Pressure and permeability measurements from sampled intervals; and
- Sidewall core sample laboratory results (if collected).

Any suspected contamination or anomalous data will be reported to the EPA-Region 9 within 24 hours of the operator's receipt of the information.

8.2 QUARTERLY MONITORING REPORTS

Quarterly reports will be submitted to EPA-Region 9 within 45 days of the end of each quarter. They will include the data collected during the quarter, as well as documentation to demonstrate that the pressure monitoring and fluid sampling events were conducted according to the approved Monitoring Well Plan. Any suspected contamination or anomalous data will be reported to the EPA-Region 9 within 24 hours of the operator's receipt of the information

8.2.1 INJECTION ZONE MONITORING

The Injection Zone Monitoring quarterly reports will include the following information collected from each monitoring well:

- Weekly formation pressure data for the quarter, which will include maximum and mean values, and include applied corrections, if necessary. The data may be presented in tables

and on graphical plots that show maximum formation pressure since the inception of monitoring the interval; and

- Monthly formation fluid analytical results for the quarter. The results will be presented in tables that provide the analytical results of each parameter since the inception of monitoring the interval. The original certified laboratory results from each sampling event during the quarter will be provided for review.

HCC will submit quarterly Injection Zone Monitoring quarterly reports to EPA-Region 9 until the wells are plugged back to monitor the base of the USDW.

8.2.2 USDW MONITORING REPORT

The USDW Monitoring quarterly reports will include the following information collected from each monitoring well:

- Weekly formation pressure data for the quarter, which will include maximum and mean values, and include applied corrections, if necessary. The data may be presented in tables and on graphical plots that show maximum formation pressure since the inception of monitoring the interval; and
- Monthly formation fluid analytical results for the quarter. The results will be presented in tables that provide the analytical results of each parameter since the inception of monitoring the interval. The original certified laboratory results from the sampling events will be provided for review.
 - The sampling frequency will be reduced from monthly to quarterly after 9-months, or when a statistically adequate dataset is generated. At such time, the quarterly formation analytical results will be reported.

After 2 years, HCC will consult with EPA-Region 9 regarding the frequency of the sampling and reporting schedule of the USDW monitoring interval.

9 PLUGGING AND ABANDONMENT

9.1 PLUGGING AND ABANDONMENT OF MONITORING WELLS

The cement-filled method will be employed to plug and abandon the monitoring wells. This technique involves displacing the cement through a work string which has been run into the casing. The cement slurry is pumped down the work string and up the annulus to a calculated height which would balance the cement inside and outside the work string. The work string is then slowly pulled out of the cement leaving a solid, uniform plug. After waiting for cement to gain compressive strength, the plug is tagged and then the process repeats itself. The cementing operation will be conducted with approximately three 750-ft plugs to fill the wellbore from the plugged back depth of ~2,200 ft to surface. The plugs will be set at depths consistent with EPA-Region 9 plugging standards to prevent a pathway for upward fluid migration within the AOR.

Finally, after all cement plugs are set, the well casings will be cut off 6-ft below grade and capped by welding a ½ inch steel plate to the outermost casing string.

The plugging and abandonment procedures are described as follows:

- 1 Notify the county, state, and EPA-Region 9 regulatory agencies of the Mechanical Integrity Test (MIT) schedule. Conduct an annulus pressure test. Rig down the wireline unit.
- 2 Prepare the well and location for plugging. Remove the wellhouse (if present), well monitoring equipment, and wellhead injection tubing.
- 3 Move in and rig up a frac tank and fill with 500 bbls mixing water for cement.
- 4 Move in and rig up the workover unit with Blow Out Preventer (BOP) equipment and a 2 7/8-inch work string.
- 5 Remove the wellhead and install the BOP equipment and stripper head.
- 6 Unseat the packer and displace the annular fluid by flushing annulus with 200 bbls of potassium chloride brine.
- 7 Trip out of the hole laying down the 2 7/8-inch injection tubing and packer.
- 8 Rig up the wireline unit and run a casing inspection log and a cement bond/variable density log from total depth to the surface. Pick up and run a wireline set cement retainer to ~2,150 ft (50 ft above top perforation) in the 5 1/2-inch protection casing. Rig down the wireline unit.
- 9 Trip in hole to the cement retainer with 2 7/8-inch workstring.
- 10 Rig up cement service equipment. Cement shall be Class "A" (or comparable), weighing 15.6 pounds/gallon. Pressure test the surface lines as required.

- 11 Squeeze cement below cement retainer and into perforations in the USDW. Since cement is below retainer, do not wait on cement to set.
- 12 Using necessary spacer fluids and pre-flushes, spot sufficient Class "A" (or comparable) cement slurry to develop a cumulative 750-ft column (minimum). Pull the tubing up 750 ft and reverse out excess cement. Catch a sample of cement to check curing time and compressive strength. Allow the cement to set overnight (8-hour minimum) before tagging top of plug to confirm proper setup and location. Pressure test the plug to the pressure recommended by the EPA-Region 9. If cement is set adequately, proceed to Step 13. Otherwise, spot additional cement on top of the first plug, as before, to achieve a cumulative 750-ft cement plug. Allow cement to set for a longer period, if necessary.
- 13 Pull tubing up to 1,400 ft. Place Class "A" (or comparable) cement plug from 1,400 ft to 650 ft. Pull the tubing out of the hole. Shut down for 8 hours, or as required; then, tag the plug to confirm location.
- 14 Run in the hole and tag cement. Pull tubing up to 640 ft. Place Class "A" (or comparable) cement plug from 650 ft to surface.
- 15 Cut casing strings ± 6 ft below ground surface.
- 16 Weld a ½ inch steel plate across the 7- inch casing. Inscribe on plate, in a permanent manner, the following information: (1) operator name, (2) closure date, and (3) Underground Injection Control (UIC) permit number.
- 17 Release all equipment and clean up the location.
- 18 Submit closure data to the EPA-Region 9, California Department of Water Resources, and county.

Once closure operations are complete and the well is officially plugged and abandoned, a closure report certifying that the well or wells were closed in accordance with applicable requirements, will be submitted to the proper agencies within 30 days of completed plugging operations. When plugging and abandonment is complete, HCC will submit certification to the EPA-Region 9 and Merced County (by HCC and by a licensed, professional engineer with current registration in California, who is knowledgeable and experienced in practical drilling engineering and who is familiar with the special conditions and requirements of injection well construction) that the injection well has been closed.

9.2 FINANCIAL ASSURANCE OF MONITORING WELLS

Based on the scope in Section 9.2, the cost estimate to plug and abandon each monitoring well is approximately \$152,000 (Appendix E). This cost estimate includes 20% contingency.

TABLES



Table 2-1 Artificial Penetrations within 2.5-mile AOR

AP	OPERATOR LEASE AND WELL NO. LOCATION API NO.	TOTAL DEPTH (FEET)	STATUS PLUG DATE	CSG TYPE	SIZE (IN)	DEPTH (FEET)	CASING DATA CSG PULLED	TOP CMT	VOL CMT (SACKS)	CEMENT PLUGS INTERVAL (FEET)	CMT VOL (SACKS)	MUD WEIGHT (LBS)	DISTANCE FROM WD-3 (MILES)	ΔP AT AP	CASING & PLUGGING EVALUATION
1	C. F. Braun & Company C. B. Young 1 T5S R10 E Sec 14 800' S and 900'E NW corner Sec 14 04-047-20040	9,676	P&A 1/13/1976	Surface	9.625	945	0	Surface	475	1,110 to 865 60 to 16	120 50	10.5	0.83	9.44	<ul style="list-style-type: none"> SC not set below USDW No cement plugs below USDW No cement plug above IZ Mud filled open hole
2	Schusterman Operating Co. Inexo-Nyman Unit 1 T06S R10E Sec 2 1571' N & 1070' E from SW cor Sec2 04-047-20019	9,300	P&A 12/21/1971	Conductor Surface	16 8.625	927	0 0			977 to 656 32 to 6	100 10	10.8	0.74	9.48	<ul style="list-style-type: none"> SC not set below USDW No cement plugs below USDW No cement plug above IZ Mud filled open hole
3	Atlantic Oil Co. Hilmar 1 T06 R10E Sec 10 1245' S & 1170' E from NW cor Sec 10 04-047-20036	8,100	P&A 5/22/1974	Surface	10.75	1,012	0	Surface	804	1,095 to 924 30 to 5	110	10.7	0.81	9.08	<ul style="list-style-type: none"> SC not set below USDW No cement plugs below USDW No cement plug above IZ Mud filled open hole
4	Hillard Oil and Gas Inc. Deus 1 T06 R10E Sec 4 1980' W & 660' N from Cor Sec 4 04-047-20054	8,013	P&A 5/5/1977	Surface	8.625	812	0	Surface Surface	360	860 to 708 60 to 0	75 25	10.1	1.49	7.77	<ul style="list-style-type: none"> SC not set below USDW No cement plugs below USDW No cement plug above IZ Mud filled open hole
5	Amerada Petroleum Corp. Lundquist Unit 1 T06S R10E Sec 16 1200' S & 1200' W from NE cor Sec 16 04-047-20007	9,775	P&A 1/24/1969	Conductor Surface	18 10	55 202	0 0	Surface Surface	200	766 to 664 25 to 15	60	11.07	1.40	7.96	<ul style="list-style-type: none"> SC not set below USDW No cement plugs below USDW No cement plug above IZ Mud filled open hole
6	Emerald San Joaquin Corp. Hillman-Genzoli Gas Unit 1 T06S R10E Sec 4 1,478' FNL & 1,160 FWL 04-099-20048	11,800	P&A 10/11/2000	Conductor Surface Production	16 10.75 7.625	48 2,032 10,270	0 0 0	Surface Surface	216 965 525	11,307 to 10,803 10,330 to 10,170 1,970 to 100 1,013 to 883 50 to 5	100 70 1,770 100	11	2.22	6.98	<ul style="list-style-type: none"> SC set below USDW Cemented Prod casing with cement above IZ Cement plug near base of USDW No cement plug above IZ
7	Phillips Petroleum Co. Clauss 1 T06S R10E Sec 21 04-047-20083	11,594	P&A 4/7/1992	Conductor Surface Production	16 9.625 7	40 1,522 10,475	0 0 0	Surface Surface 8,500	746 395	11,425 to 11,207 10,540 to 10,325 1,100 to 950 50 to 10	38 42 50	14.1	2.31	6.85	<ul style="list-style-type: none"> SC not set below USDW Cemented Prod casing with cement, not above IZ No cement plugs below USDW No cement plug above IZ
9	Bob Ferguson Independent Ferguson No. 1-24 T06S R10E Sec 24 100' N & 1250' E of West 1/4 cor 04-047-20006	4,584	P&A 12/8/1968	Surface	9.625	512	0	Surface	260	565 to 450 10 to 0	60	9.6	2.26	6.88	<ul style="list-style-type: none"> SC not set below USDW No cement plugs below USDW No cement plug above IZ Mud filled open hole



TABLE 3-2
CALCULATED R_{wa} AND SALINITY VALUES FOR WD-3

WD-3 DEPTH (Ft KB)	Temperature Gradient	Temp (°F)	R_T (Resistivity Deep)	ϕ Porosity (Density)	(a) Constant	(m) Constant	R_{wa}	NaCl Chart (ppm)
0	0.0185	74.2						
590	0.0185	85.1	38.0	0.32	0.62	2.15	5.29	850
800	0.0185	89.0						
814	0.0116	89.2	4.5	0.36	0.62	2.15	0.81	6,000
890	0.0116	90.0	5.0	0.40	0.62	2.15	1.12	4,400
1,156	0.0116	93.1	3.7	0.36	0.62	2.15	0.66	7,100
1,465	0.0116	96.7	3.0	0.36	0.62	2.15	0.54	8,300
1,534	0.0116	97.5	2.7	0.34	0.62	2.15	0.43	10,100
1,587	0.0116	98.1	2.0	0.43	0.62	2.15	0.53	8,300
1,639	0.0116	98.7	3.8	0.40	0.62	2.15	0.85	5,100
1,670	0.0116	99.1	3.3	0.35	0.62	2.15	0.56	8,000
1,709	0.0116	99.5	3.0	0.36	0.62	2.15	0.54	8,050
1,986	0.0116	102.8	2.5	0.32	0.62	2.15	0.35	12,500
2,050	0.0116	103.5	2.1	0.36	0.62	2.15	0.38	11,400
2,145	0.0116	104.6	3.0	0.25	0.62	2.15	0.25	17,700
2,314	0.0116	106.6	2.0	0.31	0.62	2.15	0.26	16,500
2,512	0.0116	108.9	2.2	0.31	0.62	2.15	0.29	14,500
2,646	0.0116	110.4	1.2	0.36	0.62	2.15	0.22	19,500
3,300	0.0037	118.0						
3,312	0.0037	118.0	2.5	0.30	0.62	2.15	0.30	12,700
3,408	0.0037	118.4	2.3	0.32	0.62	2.15	0.32	12,000
3,437	0.0037	118.5	2.0	0.30	0.62	2.15	0.24	16,000
3,550	0.0037	118.9	3.0	0.28	0.62	2.15	0.31	11,900
3,624	0.0037	119.2	2.9	0.30	0.62	2.15	0.35	10,500
3,788	0.0037	119.8	2.1	0.33	0.62	2.15	0.31	12,000
4,115	0.0037	121.0						

The expression for apparent water resistivity R_{wa} is: $R_{wa} = \frac{(\Phi_m \times R_t)}{a}$

NOTES:

- Salinity concentrations are determined using Schlumberger's 2009 Edition "Resistivity of NaCl in Water Solutions", Gen-6 (formally Gen-9) chart.
- R_{wa} is determined using an Archie based equation: $R_{wa} = R_t \times (\text{Porosity}^{2.15}) / 0.62$ assuming the saturation of water (S_w) equals 1.
- Temperature is determined by using Surface Temperature and Max Temperatures (outlined in bold) obtained from the Well Log and interpolating in-between.



TABLE 6-1

SAMPLING PARAMETERS, PRESERVATION, VOLUMES, AND HOLDING TIMES

PARAMETER	ANALYTICAL METHOD	PRESERVATION	CONTAINER ¹	VOLUME ²	MAX HOLDING TIME
Potassium (K)	USEPA 200.7	Filter on site ³ , acidify to pH<2.0 w/HNO ₃	P	1L	6 months
Sodium (Na)	USEPA 200.7	Filter on site ³ , acidify to pH<2.0 w/HNO ₃	P		6 months
Calcium (Ca)	USEPA 200.7	Filter on site ³ , acidify to pH<2.0 w/HNO ₃	P		6 months
Magnesium (Mg)	USEPA 200.7	Filter on site ³ , acidify to pH<2.0 w/HNO ₃	P		6 months
Chloride (Cl)	USEPA 300.0	Cool to 4°C ⁴	P	250 ml	28 days
Sulfate (SO ₄)	USEPA 300.0	Cool to 4°C ⁴	P		28 days
Total Dissolved Solids (TDS)	SM 2540C	Cool to 4°C ⁴	P		7 days
Specific Conductance (Conductivity)	SM 2510B	Cool to 4°C ⁴	P		28 days
pH	--	None required	T, P, G	25 ml	--
Specific Gravity	--	None required	T, P, G	25 ml	--

NOTES:

1. P=Plastic (polyethylene), G=Glass, T=Fluorocarbon resins (PFTE, Teflon, FFP, PFA, etc.)
2. Based on establishing baseline water quality in the first year, the owner/operator must collect a sufficient volume of fluid to allow for the analysis of one replicate.
3. Filtration, utilizing a 0.45 µm membrane, should take place as soon as possible after sample collection. Glass or plastic filtering apparatus using plain, non-grid marked, membrane filters are recommended to avoid possible contamination.
4. Shipping containers (cooling chest with ice or ice pack) should be certified as to the 4°C temperature at the time of sample placement into these containers. Preservation of samples requires that the temperature of collected samples be adjusted to 4°C immediately after collection. Shipping coolers must be at 4°C and maintained at 4°C upon placement of the sample and during shipping. Maximum-minimum thermometers are to be placed into the shipping chest to record temperature history. Chain-of-custody forms will have Shipping/Receiving and In-transit (max/min) temperature boxes for recording data and verification.

FIGURES

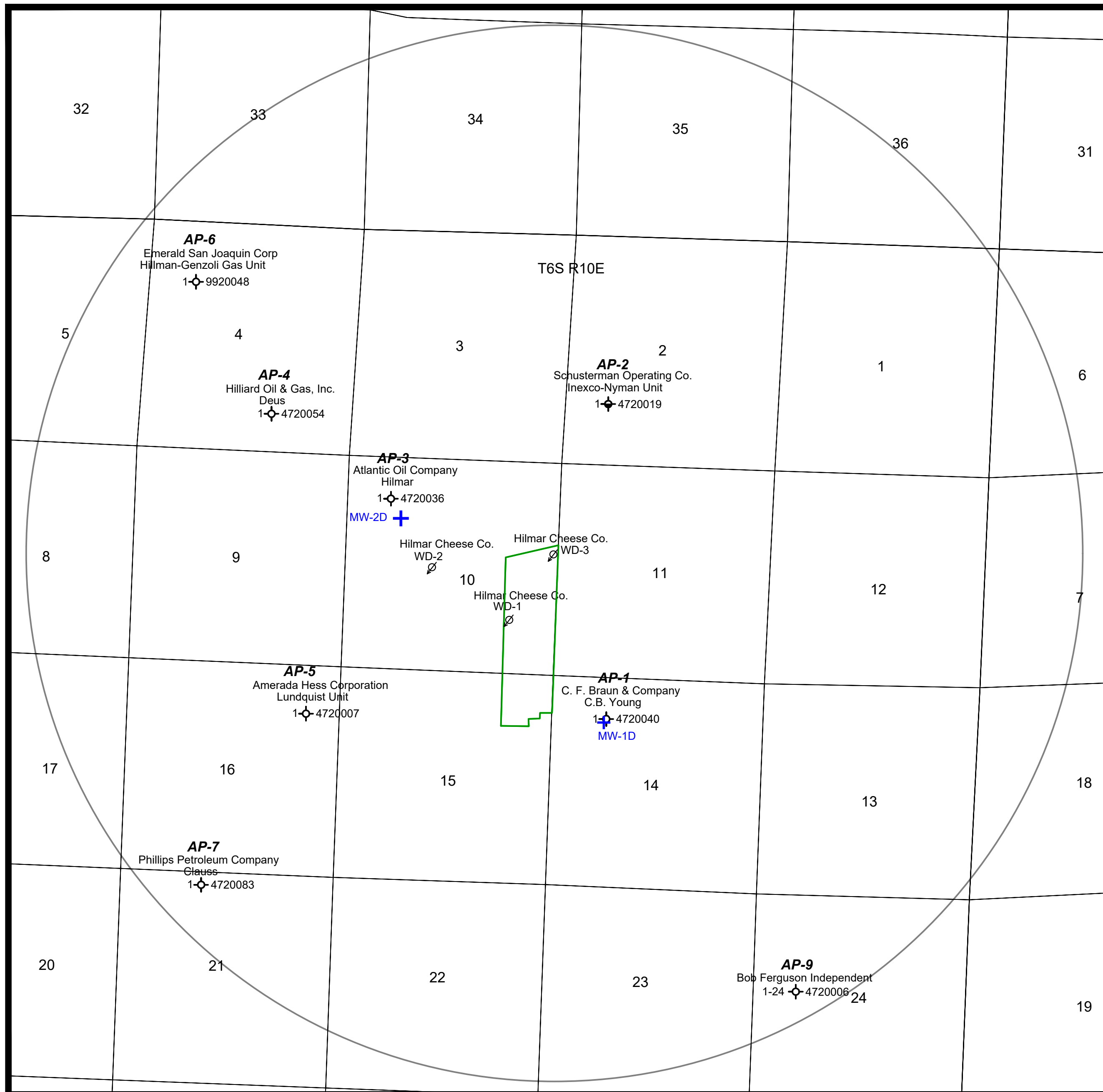

LEGEND

- ARTIFICIAL PENETRATIONS
- INJECTION WELL
- MONITOR WELL

2.5-MILE AREA OF REVIEW
 FACILITY BOUNDARY

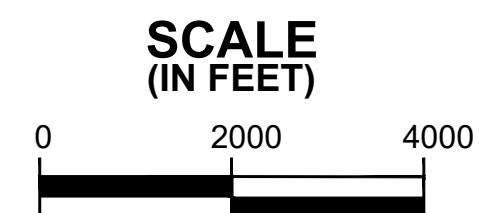
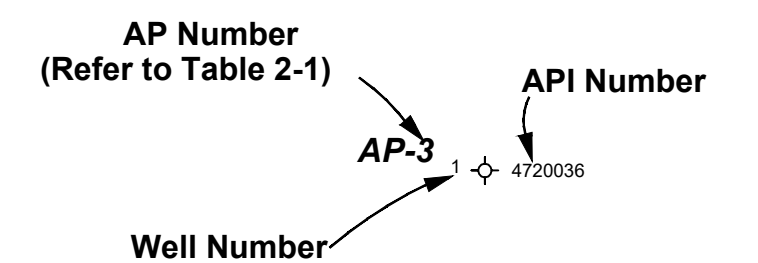

WSP USA Inc.
 8212 Kelwood Ave
 Baton Rouge, LA 70806
 TEL: (225) 753-2561

FIGURE 2-1

HILMAR CHEESE COMPANY
 MERCED COUNTY, CALIFORNIA

**SITE MAP AND
 AREA OF REVIEW**

DATE: 12/11/2020	CHECKED BY: KMG	JOB NO: 192024F
DRAWN BY: WDD	APPROVED BY: GEM	DWG NO:

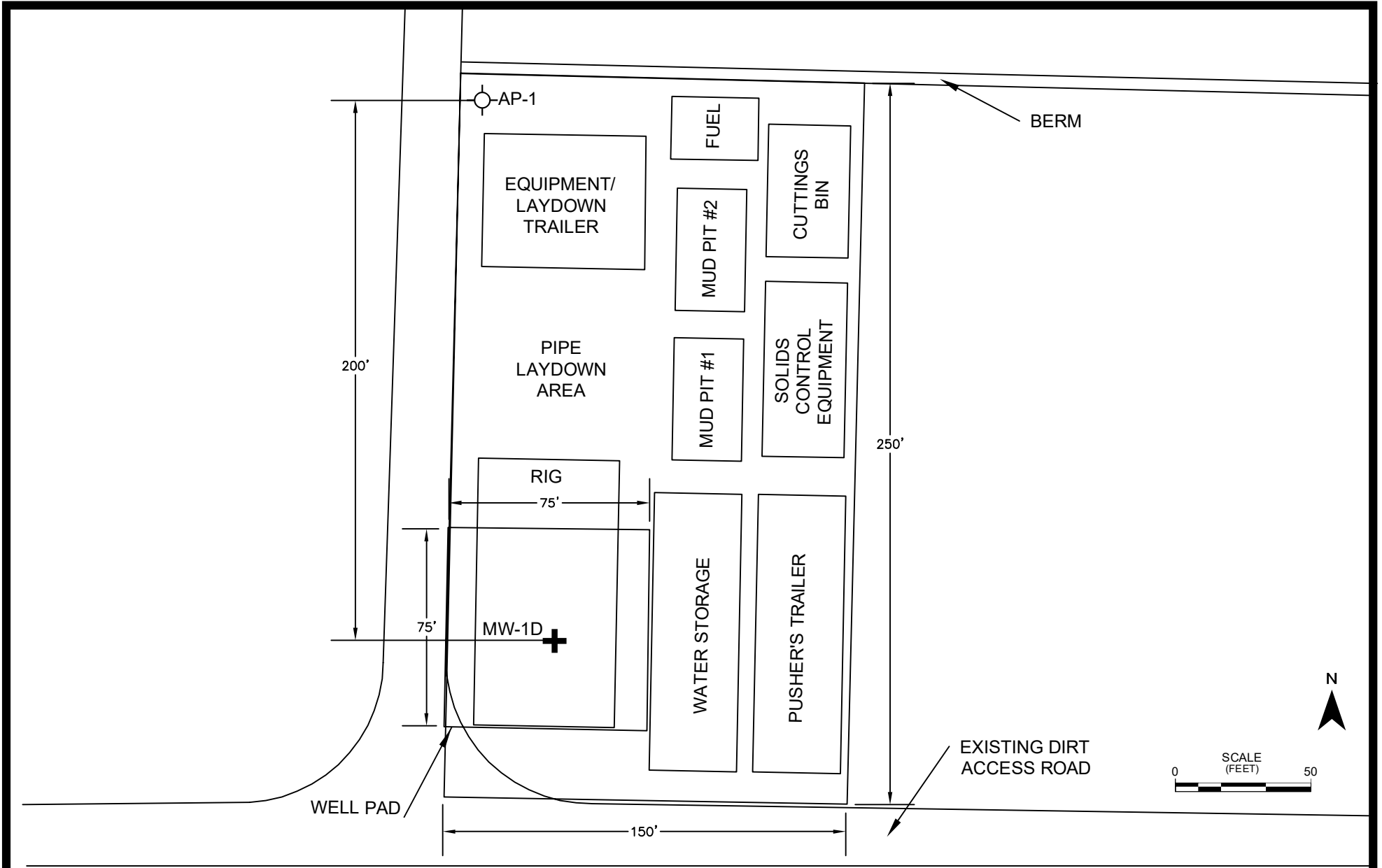

WSP USA Inc.
 8212 Kelwood Ave.
 Baton Rouge, LA 70806
 TEL: (225) 753-2561

HILMAR CHEESE COMPANY
MERCED COUNTY, CALIFORNIA

MW-1D SITE LOCATION MAP

Job No. 192024F

Drawn: WDD

Checked: KMG

Approved: GEM

Date: 12/11/2020

Scale: None

Figure No. 3-1

AP-3
 Bottomhole Location:
 Lat: 37.43008, Long:
 -120.86389 (100 ft
 from AP-3)



EXISTING DIRT
 ACCESS ROAD

520'
 (NTS)

75'

75'

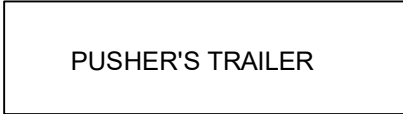
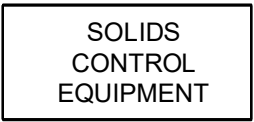
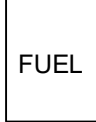
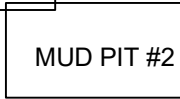
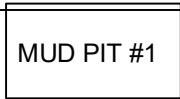
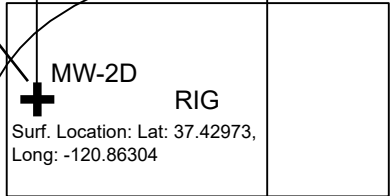

200'

200'

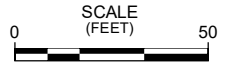

WSP USA Inc.
 8212 Kelwood Ave.
 Baton Rouge, LA 70806
 TEL: (225) 753-2561

**HILMAR CHEESE COMPANY
 MERCED COUNTY, CALIFORNIA**

MW-2D LOCATION MAP

Job No. 192024F

Drawn: WDD

Checked: KMG

Approved: GEM

Date: 3/11/21

Scale: None

Figure No. 3-2

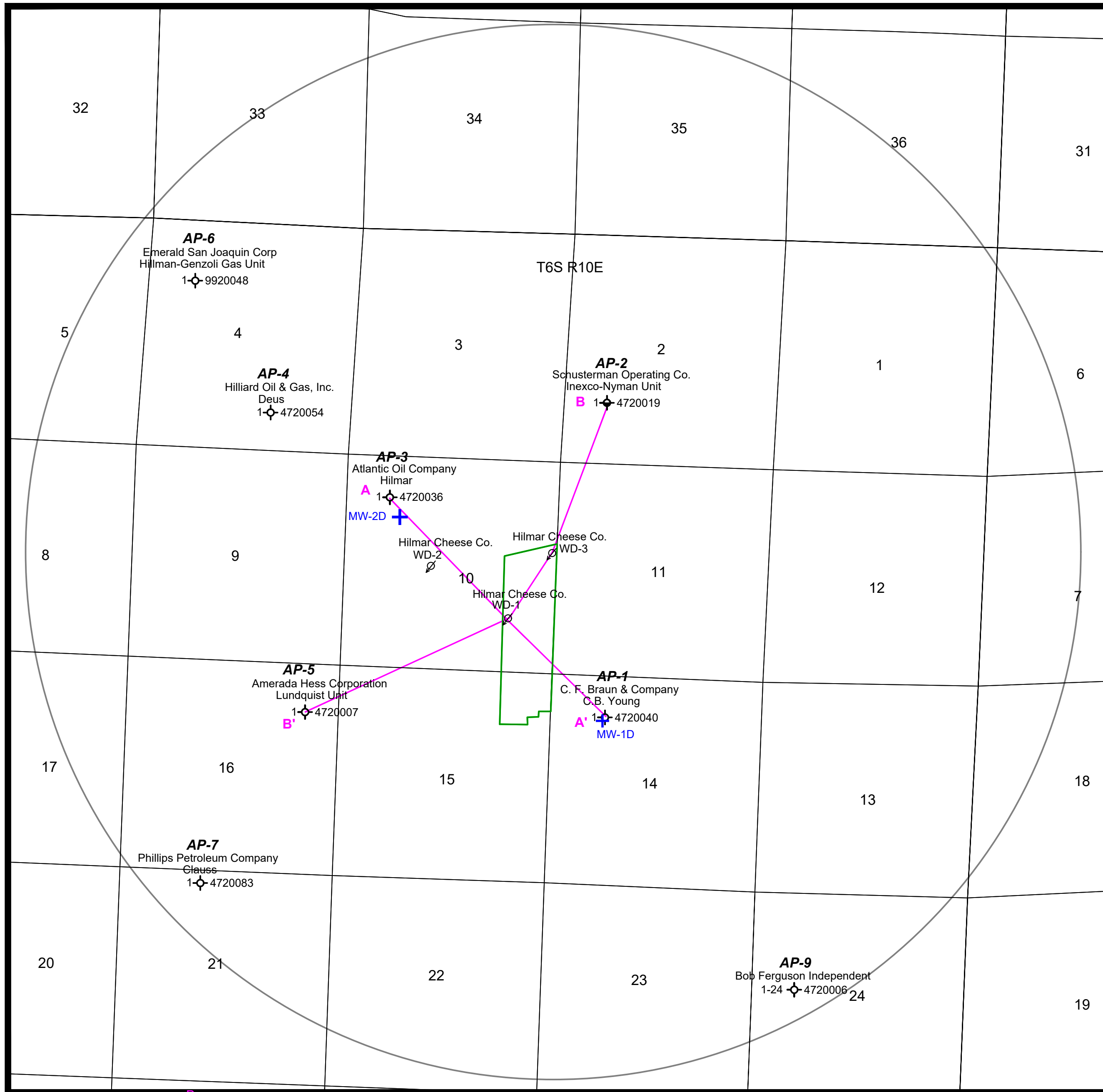

LEGEND

- ARTIFICIAL PENETRATIONS
- INJECTION WELL
- MONITOR WELL
- 2.5-MILE AREA OF REVIEW
- FACILITY BOUNDARY
- GEOLOGIC CROSS SECTIONS

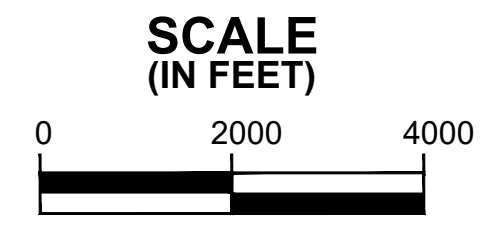
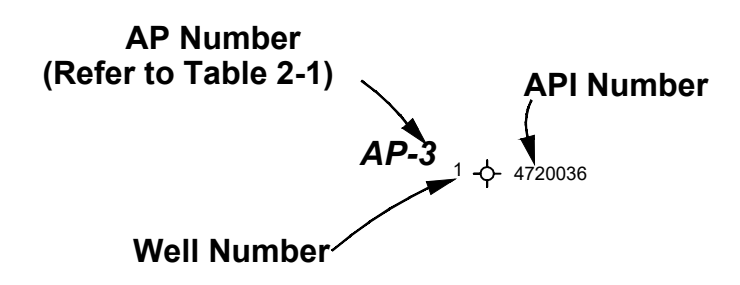

	WSP USA Inc. 8212 Kelwood Ave Baton Rouge, LA 70806 TEL: (225) 753-2561	
FIGURE 3-3 HILMAR CHEESE COMPANY MERCED COUNTY, CALIFORNIA		
CROSS-SECTION LINES LOCATION MAP		
DATE: 12/11/2020	CHECKED BY: KMG	JOB NO: 192024F
DRAWN BY: WDD	APPROVED BY: GEM	DWG NO:

NORTHWEST

SOUTHEAST

A

A'

AP-3
 ATLANTIC OIL CO.
 HILMAR NO. 1
 SEC. 10 T6S R10E
 TD: 8,100' KB: 110'
 DRY HOLE
 TOP OF LOG: 1,013'
 API NUMBER 04720036

HILMAR CHEESE CO.
 HCC-WD-3
 SEC. 10 T6S R10E
 TD: 4,180' KB: 114'
 CLASS I INJECTION WELL
 TOP OF LOG: 800'

AP-1
 C.F. BRAUN & COMPANY
 CB YOUNG NO. 1
 SEC. 14 T6S R10E
 TD: 9,676' KB: 102'
 DRY HOLE
 TOP OF LOG: 945'
 API NUMBER 04720040

Subsea Depth
Sea Level

Subsea Depth
Sea Level

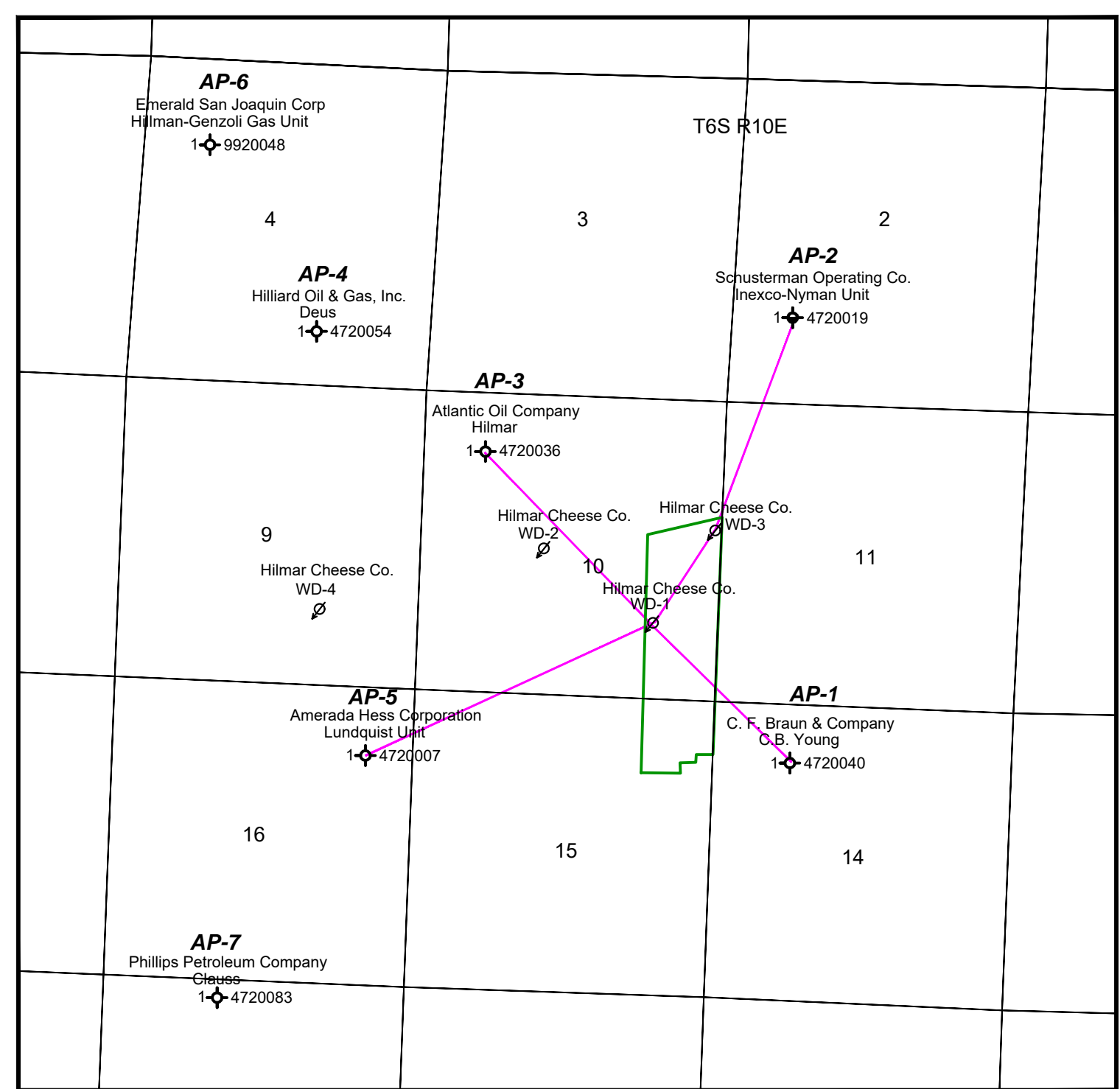
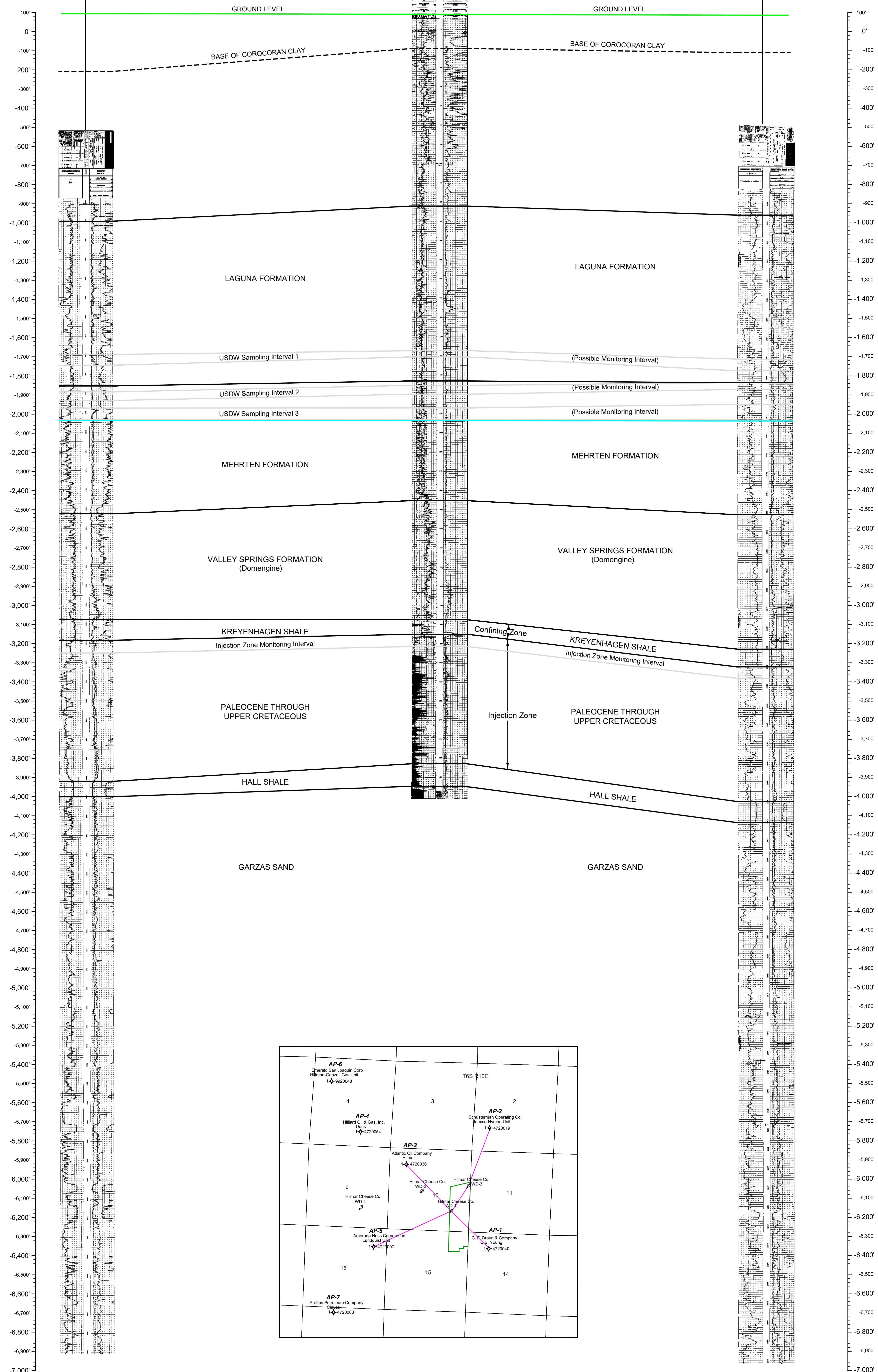

LEGEND:
 - - - - - BASE OF CORCORDAN CLAY
 _____ BASE USDW IN PERMIT

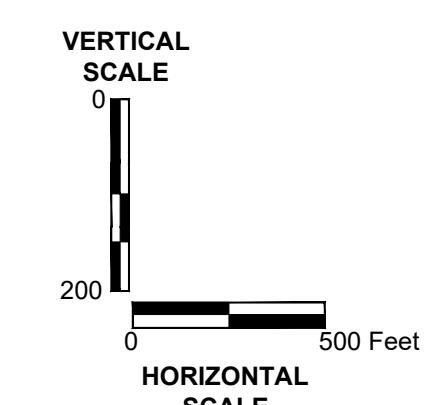

WSP WSP USA Inc.
 8212 Kelwood Ave.
 Baton Rouge, LA 70806
 TEL: (225) 753-2561

FIGURE 3-4
HILMAR CHEESE COMPANY
MERCED COUNTY, CALIFORNIA

NORTHWEST TO SOUTHEAST
GEOLOGIC CROSS-SECTION A - A'

DATE: 12/11/2020 | CHECKED BY: KMG | JOB NO: 192024F
 DRAWN BY: WDD | APPROVED BY: GEM | DWG. NO:

NORTHEAST

SOUTHWEST

B

B'

AP-2
 SCHUSTERMAN OPERATING CO.
 INEXCO-NYMAN NO. 1
 SEC. 2 T6S R10E
 TD: 9,300' KB: 129'
 DRY HOLE
 TOP OF LOG: 927'
 API NUMBER 04720019

HILMAR CHEESE CO.
 HCC-WD-3
 SEC. 10 T6S R10E
 TD: 4,180' KB: 114'
 CLASS I INJECTION WELL
 TOP OF LOG: 800'

HILMAR CHEESE CO.
 HCC-WD-1P
 SEC. 10 T6S R10E
 TD: 4,100' KB: 105'
 CLASS I INJECTION WELL
 TOP OF LOG: 812'

AP-2
 AMERADA HESS CORP.
 LUNDQUIST NO. 1
 SEC. 16 T6S R10E
 TD: 9,775' KB: 100.69'
 DRY HOLE
 TOP OF LOG: 716'
 API NUMBER 04720007

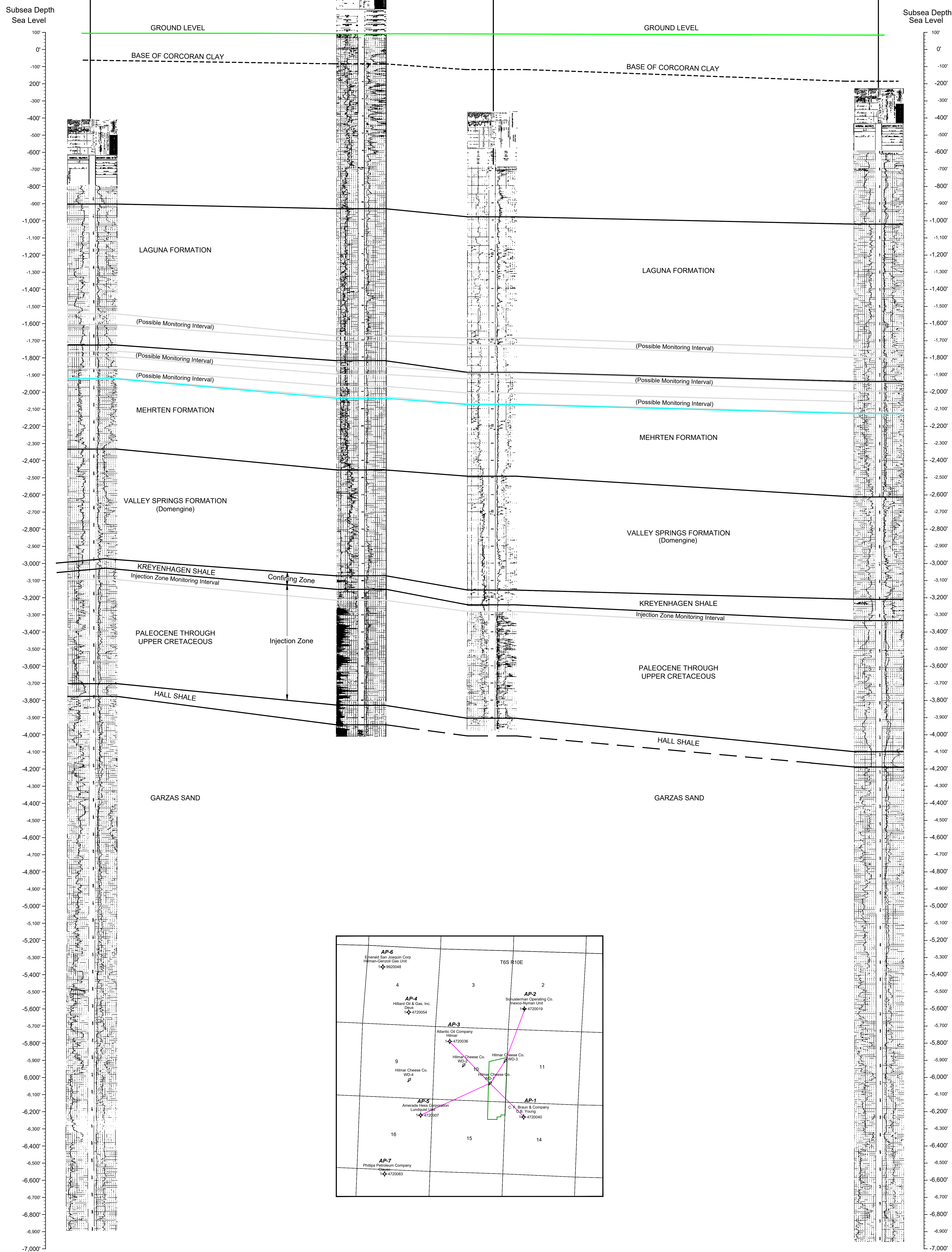

LEGEND:
 - - - - - BASE OF CORCORDAN CLAY
 _____ BASE USDW IN PERMIT

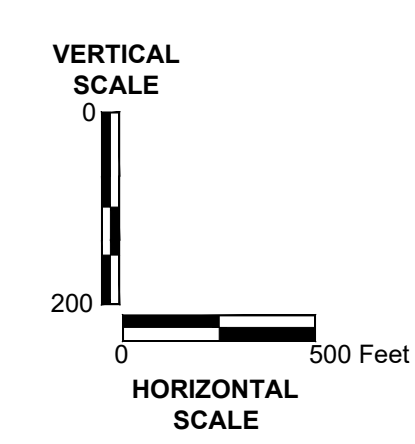

WSP WSP USA Inc.
 8212 Newwood Ave.
 Baton Rouge, LA 70806
 TEL: (225) 753-2561

FIGURE 3-5
 HILMAR CHEESE COMPANY
 MERCED COUNTY, CALIFORNIA

**NORTHEAST TO SOUTHWEST
 GEOLOGIC CROSS-SECTION B - B'**

DATE: 12/11/2020 CHECKED BY: KMG JOB NO: 192024F
 DRAWN BY: WDD APPROVED BY: GEM DWG. NO:

ALL DEPTHS ARE ESTIMATED

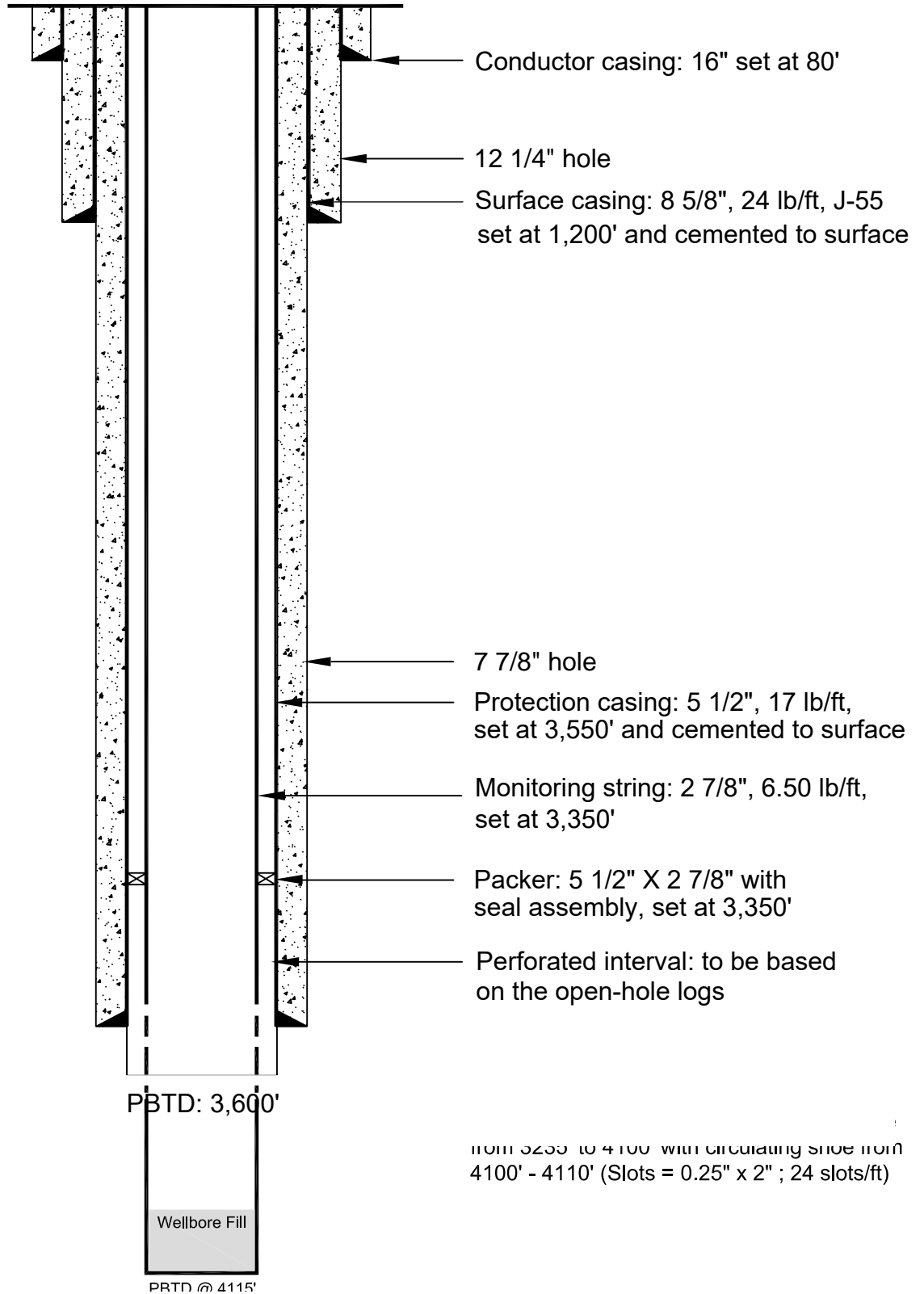

Revision 1 - January 2017 - 50924A



HILMAR CHEESE COMPANY
HILMAR, CALIFORNIA

MW-1D PROPOSED WELLBORE SCHEMATIC

Project No. 192024F

Date: 02/18/2020

Scale: NTS

FIGURE 4-1Q.3-1

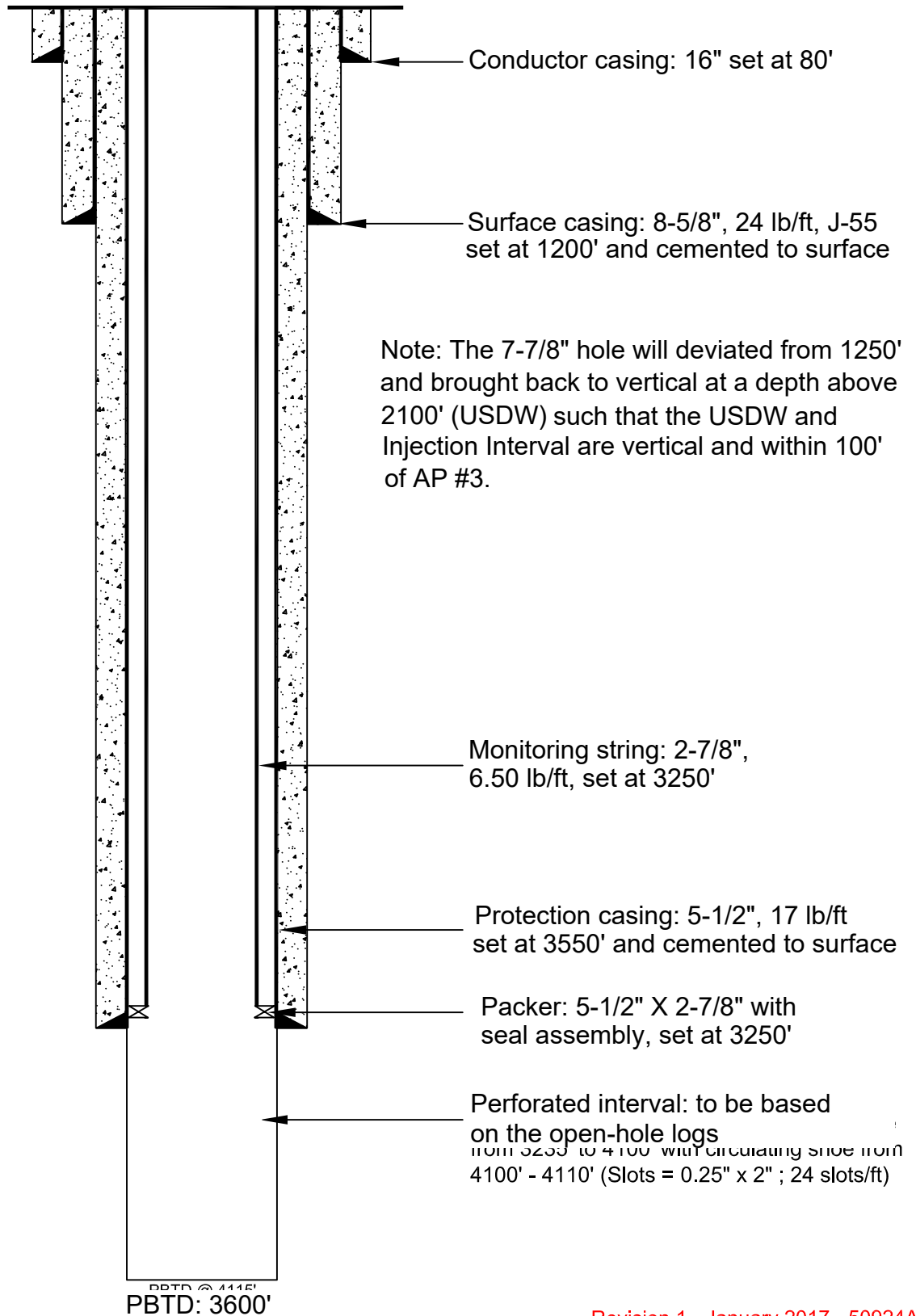

Revision 1 - January 2017 - 50924A



HILMAR CHEESE COMPANY
 HILMAR, CALIFORNIA

MW-2D Proposed Wellbore Schematic

Job No. 50924A

Design: DB

Drawn: WDD

Checked: XXX

Date: 3/11/2021

Scale: NTS

FIGURE 4-2 1

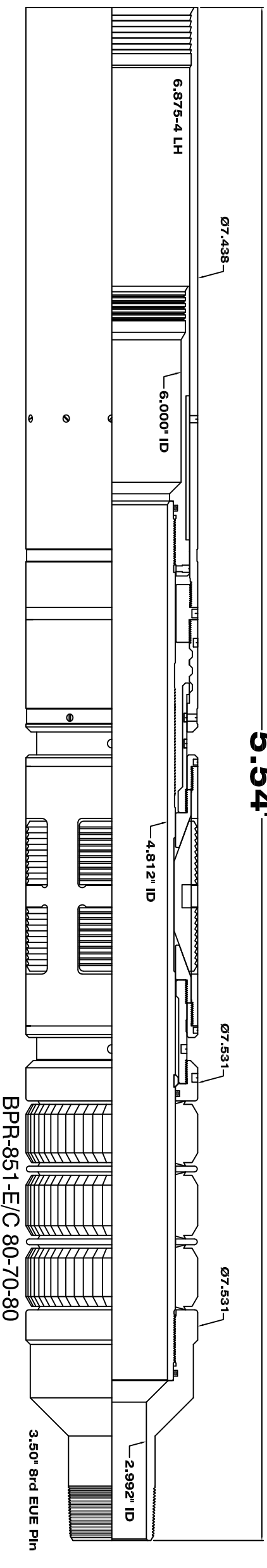
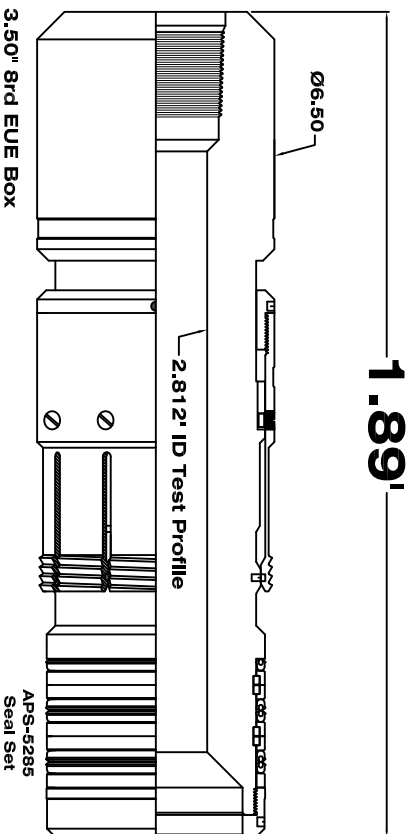

1.89'

5.54'

FIGURE 4-3
Generic Packer Assembly
with Seal Assembly

Model 12 Completion System
 Model 12 Anchor Seal Assembly (Carbon Steel)
 Model 12 Disposal Packer (Carbon Steel)

DPI Proposal No.:	N/A	Scale:	N/A	WSP Project No.:	192024F	Contact:	N/A
Well No.:	Monitor Well 1 or 2	Drawn By:	N/A	Date:	September 2020	Contact Phone No.:	N/A

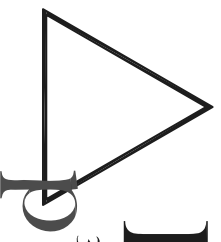

Delta P, Inc.

306 Hwy 26 East - Poplarville, MS 39470
 601/403-8100 - 601/403-8180 fax

BHTA, 3 1/8"3M X 1/2"NPT
Tapped Cap w/3 1/2"EUE
Internal Lift Threads
3ea Gate Valve Assemblies
3 1/8"3M HWO, DDNL, FE
Studded Tee Assembly
3 1/8"3M Run X Outlet
Adapter, FXS, 11"3M X
3 1/8"3M w/3 1/2" Single P
Seal Bottom

Assembly Items:
5ea R31 Ring Gasket
8ea 7/8" X 6 1/2" Studs w/Nuts

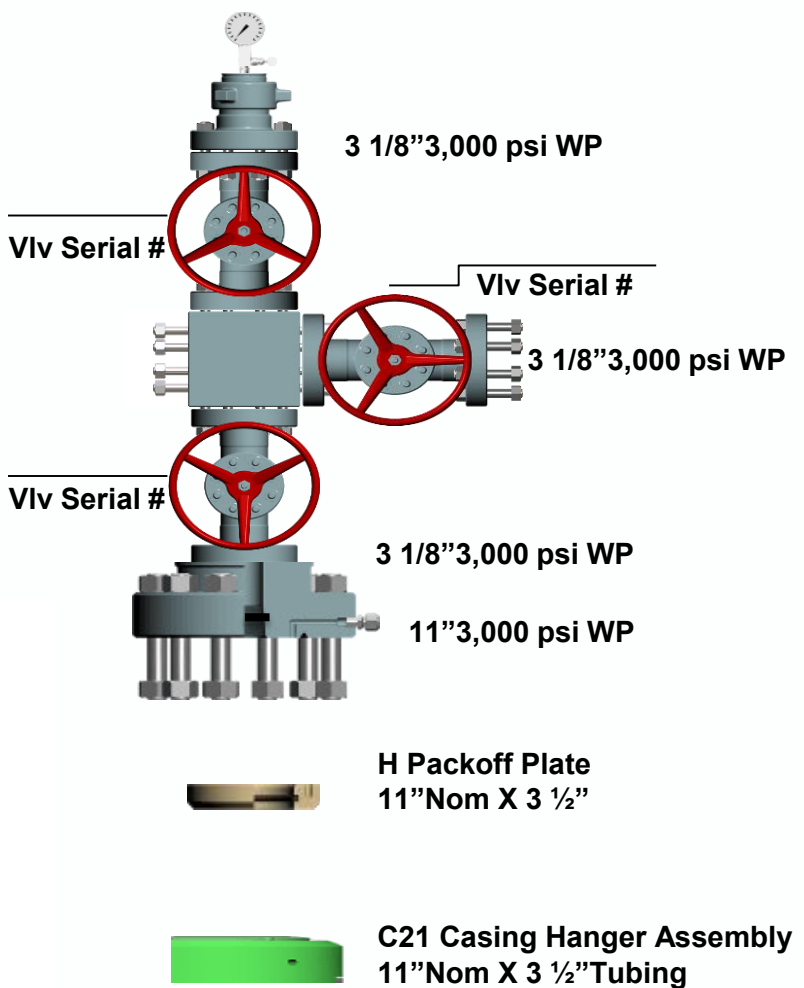

T & L Oilfield
Services,
Inc.

FIGURE 4-4
Generic Wellhead and Casing Head

Assembly Components:

**Casing Head, 11"3M X 8 5/8" SOW w/
2ea 2 1/16"EFO, 1 1/2" Sharp Vee VR Plug,
24ea 7/8" X 6" B7 Black Studs w/Nuts,
3ea R24 Ring Gaskets, 2ea 2 1/16"5M X 2" LP
CMPN Flgs, 2 1/16"5M Gate Valve, 2ea Bull Plugs
2"LP X 1/2" NPT, 1ea Body Grease Fitting in test port
1ea Body Grease Fitting in Left side Bull Plug**

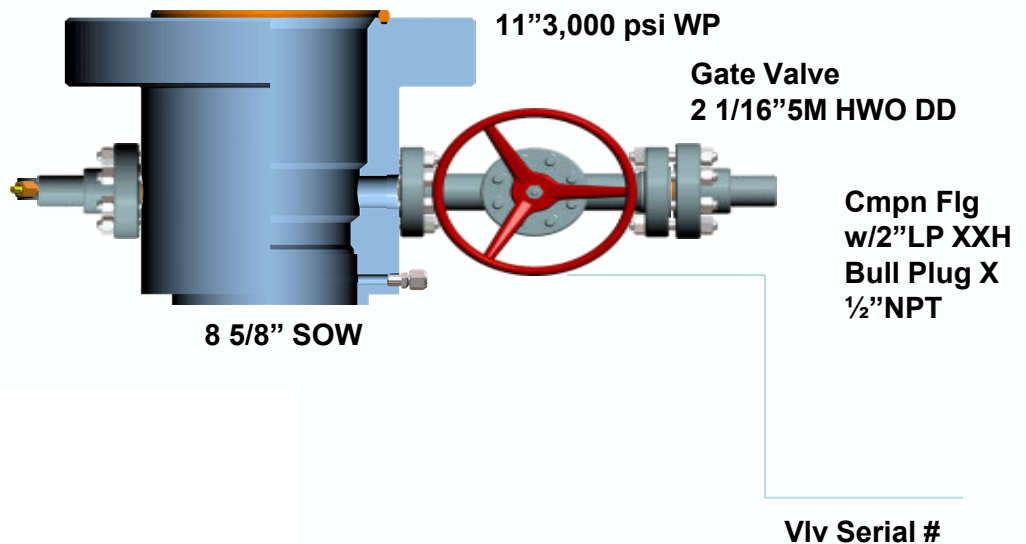

**FIGURE 4-4
Generic Wellhead and Casing Head**

APPENDICES

APPENDIX

A

AREA OF REVIEW METHODS

FROM WD-3 PERMIT APPLICATION

A. AREA OF REVIEW METHODS

Hilmar Cheese Company at Hilmar, Merced County, California, operates one Class I nonhazardous injection well: WD-3. A second Class I nonhazardous injection well, WD-2, is currently inactive and a third Class I injection well (WD-1P) was plugged and abandoned on November 22, 2015.

The Area of Review for the Hilmar injection wells was determined to be the area surrounding the Hilmar wells in which the fluid pressure in the injection zone might increase during the injection operations of the wells so that it is sufficient to move fluids from the injection zone to an unauthorized zone or to endanger other subsurface intervals. Possible pathways for fluid movement can be “natural” pathways, that is, faults and fractures of the injection zone and confining zone, or “artificial” pathways, that is, oil, gas, or water wells that penetrate the injection zone or “artificial penetrations” of the injection zone.

Natural pathways for fluid movement do not exist in the vicinity of the Hilmar injection wells. As established in Attachment F of this application, faults and fractures of the injection and confining zones are not known to be present in the vicinity of the Hilmar site. Furthermore, as demonstrated in Section H, the pressure exerted on the reservoir during injection operations, known as the injection pressure, is limited by permit so that injection by Hilmar cannot fracture the injection zone or confining zone. If fractures or faults do exist in the vicinity, the discussion in Section A.2 demonstrates that they likely will be filled with a mixture of clay, sand, and mud, and they likely will not become pathways for vertical fluid transmission.

Artificial pathways for fluid movement, specifically oil, gas, and water wells in the vicinity of the Hilmar injection wells were examined carefully to determine if they penetrate the injection zone and confining zone. No water wells penetrate the confining zone (Attachment B), but several oil and gas exploration wells were drilled through the injection zone in the vicinity of the Hilmar site. The oil and gas exploration wells (artificial penetrations), shown on Figure A-2, were examined to determine if they are constructed properly to be able to withstand the increase in injection zone fluid pressure caused by the operations of Hilmar’s injection wells.

A.1 The Non-Endangerment Standard

The “Non-Endangerment” standard requires a demonstration that pressure increases in the injection zone caused by injection cannot cause fluids to move from the injection zone or force fluids into unauthorized zones.

The outline of the worst-case predicted pressure buildup at the end of the future injection period is shown on Figure A-1. To demonstrate that the non-endangerment standard for this site has been met, all wells within the cone of influence (COI) have been reviewed in Section A.2 to determine if they meet the non-endangerment standard.

A.2 Injection Zone Pressure Buildup

Increase in injection-zone fluid pressure or pressure buildup in the injection zone caused by the Hilmar injection operations was calculated using PredictW, a proprietary analytical pressure simulator based on an exponential-integral formulation for pressure behavior in a homogeneous reservoir (Appendix A-2). The effects of Hilmar's injection operations were modeled using all historical volumes for Hilmar wells WD-1P, WD-2 and WD-3. The future injection was modeled based on 35 gpm injection into WD-3. Input parameters for pressure buildup calculations are discussed in Section F.4-2 of Attachment F. The model-generated pressure buildup contours are shown in Figure A-1. The Area of Review map is included as Figure A-2. The details of the process are provided in Appendix A-2, and PredictW input and output files are provided in Appendix A-3.

Well records and logs for oil and gas related wells available on the California Department of Oil and Gas and Geothermal Resources online database were used to construct the well schematics for casing, cementing, and to note any other well condition existed. Mud weights were obtained from the well log headers. If the mud weight was provided as pounds per cubic foot, then it was converted to pounds per gallon (ppg) by using the conversion of $(\text{lbs}/\text{ft}^3 \text{ mud}) / (62.43 \text{ lbs}/\text{ft}^3 \text{ water}) \times 8.33 \text{ lbs of water per gallon}$. Well log headers showing the mud weight measured when the wells were logged are included in Appendix A-1. The mud weights are tabulated in Table A.1-1.

The Area of Review is a fixed $\frac{1}{4}$ mile radius from the injection well or an appropriate calculated method to determine the size of the Area of Review. The Cone of Influence (COI) was calculated based on the pressure build up modeled due to injection (Figure A-2). The critical pressure buildup was calculated using the following method:

Critical Pressure Buildup: The following table shows the criteria at WD-3 just before endangerment to the USDW would occur:

WD-3

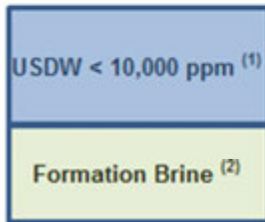

	Depth (ft below GL)	Fluid Head (feet)	Fluid Gradient (psi/foot)	Incremental Pressure Head (psi)	Cumulative Pressure Head (psia)
Top of USDW	11	11		14.7	14.7
Base of USDW ⁽³⁾	1702	1691	0.4346	734.9	749.61
Top of Injection Interval	3248	1546	0.4405	680.9	1430.54 ⁽⁴⁾

⁽¹⁾ Average TDS (5,000 ppm \approx SpGr 1.0025) used in calculations.

⁽²⁾ Specific Gravity of formation fluid from WD-3 (sample date 3/10/2011) was 1.016 which is equivalent to a fluid gradient of 0.4405 psi/ft.

⁽³⁾ Determined from evaluation of open hole logs (WSP - P.Patel).

⁽⁴⁾ Critical Pressure = Maximum allowable pressure at Top of Injection Interval to prevent formation fluid from entering USDW through uncased wellbore.

If the pressure at the top of the injection interval formation exceeds 1430.54 psia (Critical Pressure), there is a potential for formation brine to be forced into the USDW. Endangerment will not occur at WD-3 because the well maintains mechanical integrity.

An initial pressure was provided for WD-3 in the drilling and completion report; however, the veracity of the reported value cannot be verified. An estimate of the initial pressure at WD-3 will be discussed in the following paragraphs.

A falloff test was conducted on WD-3 on January 10, 2017. Analysis of the falloff test yielded p^* (an estimate of pressure at infinite shut-in time). The p^* value was 1486.56 psia at a depth of 3311 feet KB. The pressure gradient of the wellbore fluid was found to be 0.4442 psi/ft following the falloff test. The pressure was adjusted to the top of the injection interval at a depth of 3261 feet KB (3248 feet below ground level) using the fluid gradient in the wellbore. The resulting pressure at the top of the injection interval was 1453.47 psia. This pressure exceeds the critical pressure by 22.93 psi; however, as stated previously, WD-3 does not provide a pathway for endangerment.

In order to combine the reservoir pressure modeling results (Δ pressure) for WD-3 with the endangering criteria for the USDW, the original pressure at the top of the injection interval must be estimated. The modeled increase in pressure at WD-3 on January 10, 2017 was 26.69 psi. When this value is subtracted from the measured falloff pressure, p^* , at the top of the injection interval, the result is 1426.78 psia. The Critical Pressure Rise, i.e. increase in pressure which may lead to endangerment of the USDW, is the difference between the Critical Pressure and the initial pressure or 3.76 psi (1430.54 psia – 1426.78 psia).

The March 29, 2018 letter from EPA to Hilmar indicates the critical pressure rise to be 6.77 psi. Hilmar will defer to the value calculated by EPA for the critical pressure rise.

During the January 2017 MIT on WD-3, a Spinner Survey was conducted where it was shown that only 60 feet of the 500 foot injection zone is currently available for injection in this well. A log added to Appendix L.2-1 for WD-2, Production profile FBS/GR/Pressure/Temp log (Spinner log) showing 500 feet of available thickness prior to any injection conducted at WD-2. The reservoir pressure rise was modeled using current conditions, i.e. a thickness of 60 feet of available injection interval, a permeability of 700 md, and an injection rate of 35 gpm resulting in the 6.77 psi critical pressure zone occurring at an approximate radius of 2.5 miles from the site.

Non-Endangerment Determination for Wells Inside the Cone of Influence

Eight (8) wells are located inside the new cone of influence (Critical Pressure 6.77 psi): APs 1, 2, 3, 4, 5, 6, 7, and 9 and Hilmar's WD-3. Hilmar's wells are injection wells and are and will be properly constructed with the construction requirement by EPA and operated to prevent any endangerment of other zones. The dry and plugged and abandoned wells APs 1, 2, 3, 4 and 5, 6, 7, and 9 and WD-1P were examined to determine if they are constructed sufficiently to withstand pressure build up in the injection zone (Table A-1 and Table A-2). These wells do not need any corrective action.

None of the artificial penetrations endanger the USDW in this area. The well records are included in Appendix A-1.

**Table A-1
Pressure Over Balance Table**

AP Number	Wells Near Hilmar	Delta_p_psi
1	C.B. Young #1	9.44
2	Inexco-Nyman Unit #1	9.48
3	Atlantic Oil Co Hilmar 1	9.08
4	Hillard Oil and Gas Deus #1	7.77
5	Lundquist Unit #1	7.96
6	Hillman-Genzoli Gas Unit #1	6.98
7	Clauss #1	6.85
9	#1-24	6.88

APPENDIX

B

MW-1D DRILLING PLAN



Hilmar Cheese Company
Hilmar, California

Project No. 192024F

Appendix B
MW-1D Drilling Plan and
Completion Procedure

Date 12/22/2020

Page 1 of 8

Operator: Hilmar Cheese Company
Well: MW-1D Drilled near Plugged Well AP-1
City: Hilmar
County: Merced
State: California

1. Construction Procedure and Objectives

Hilmar Cheese Company (HCC) will be applying for a permit to drill monitor well MW-1D. MW-1D will be drilled into the Paleo-Cretaceous sand approximately 100 feet (this distance may change based on official surveying and needs of landowners) from the abandoned well AP-1 and approximately 4,390 feet from WD-3. The Paleo-Cretaceous sand is the sand formation that HCC injects into using injection well WD-3.

MW-1D will be used to monitor any pressure buildup and the water quality in the Injection Zone that might be occurring due to injection into WD-3.

MW-1D will subsequently be plugged back to the base of the Underground Source of Drinking Water (USDW). MW-1D will be used to monitor any pressure buildup and the water quality in the USDW that overlies the WD-3 Injection Zone that might be occurring due to injection into WD-3.

The 2 7/8- inch monitoring tubing and packer will be pulled.

Depending on where the Injection Zone from WD-3 intersects MW-1D on the open-hole logs, a cement plug with sand on top will be set above the Injection Zone Monitoring Interval.

The wellbore will be cleaned out to the top of the cement plug and the base of the USDW will be perforated based on the open-hole logs through the USDW Monitoring Interval.

Actions to be taken in case of lost circulation, over-pressured zones and stuck pipe situations are discussed in Section 9 of this Drilling Plan.

2. Detailed Well Construction Procedure

NOTE: The actual depths of where pipe will be set, size of the tubulars, cement additives and weights, and the properties of the drilling mud are estimates only and will be based on the geology of the formations drilled into.

Any significant deviation from the proposed program will require prior approval from the WSP Project Manager and HCC Cheese Company.

3. Casing Design

The length and quality of the surface casing is selected and designed to protect the freshwater aquifer associated with the Corcoran Clay. The long string and injection tubing are designed to best suit the existing subsurface formation fluid and injected fluid environment. The long string casing will also protect the base of the USDW.

The anticipated life of proposed MW-1D, including the wellhead, casings, cement, injection tubing, and packer, is estimated to be 50 years.



ANTICIPATED TUBULAR PROGRAM

Conductor Casing	0 to ±80 feet	16-inches conductor casing, wall of 0.656 inch augured or driven to refusal (±80 feet)
Surface Casing	0 to 1,200 feet	8 7/8-inch, 24 lb/ft, J-55, ST&C, ID of 8.097 inches
Protection Casing	0 to 3,550 feet	5 1/2-inch, 17.0 lb/ft, J-55, LT&C, ID of 4.892 inches
Monitoring Tubing	0 to 3,350 feet	2 7/8-inch, 6.50 lb/ft, L-80, LT&C, ID of 2.323 inches
Packer	3,350 feet	5 1/2-inch x 2 7/8-inch packer and seal assembly

Minimum Design Safety Factors:

Collapse Strength	1.125
Joint Strength	1.6
Internal Yield Pressure	1.0
Mud Weight	14.65 lb/gal

The details of the tubulars minimum design safety factors are included in Table 1 of this Drilling Plan.

All strings of casing and tubing will be certified as new with mill test reports and verification via third party positive material identification (PMI). Carbon steel tubular goods will be inspected with electromagnetic induction testing (Amolog IV or equivalent), with full length drift and special end area evaluations.

All tubular goods will be shipped with thread protectors and loaded onto trucks using wooden stripping between layers.

All tubular goods will be offloaded at the site using a forklift to protect from damage while handling. Threads will be cleaned and new thread compound will be installed prior to installation.

4. Proposed Completion Interval and Completion Type

The proposed monitor well will be completed by:

- Setting the casing through the interval to be monitored, cementing the casing in place, and perforating at the desired depths.
- The perforated interval is estimated to be from 3,285 feet to 3,350 feet KB with a gross interval thickness of approximately 65 feet.

5. Number and Location of Centralizers

On the surface casing, centralizers will be installed near the float shoe, on the collars of the second and third joints, and on every third collar thereafter or where applicable. Wall scratchers will not be used.

On the protection casing, centralizers will be installed between the float shoe and float collar at the center of the joint



between the float shoe and float collar, or where applicable. Wall scratchers will not be used.

6. Annulus Fluid

The annulus fluid will be a sodium chloride brine with oxygen scavenger, biocide, and corrosion inhibitor.

7. Logging

The anticipated logging program is as follows:

ANTICIPATED LOGGING PROGRAM

Logging Sections	Logging Services	Logging Depth Interval
Surface Hole (12 ¼-inch)	Triple Combo - Spontaneous potential, induction-resistivity, neutron-density and gamma ray, 6-arm caliper	200 to 1,200 feet
Production Hole (7 ⅞-inch)	Triple Combo - Spontaneous potential, induction-resistivity, neutron-density and gamma ray. 6-arm caliper. Compensated neutron/lithodensity	1,200 to 3,600 feet
Cased Hole (8 ⅝-inch surface casing)	Cement bond/variable density log and temperature survey	0 to 1,200 feet
Cased Hole (5 ½-inch production casing)	Cement bond/variable density log, baseline temperature survey	0 to 3,550 feet

8. Proposed Drilling Plan

The following drilling and completion procedure has been designed for the installation of proposed monitor well MW-1D. A schematic of the rig footprint is included as Figure 3-1 of the Monitoring Well Plan.

Survey and prepare the location for all-weather operations. Install an 8-foot diameter corrugated metal pipe cellar by 4 feet deep.

Drilling water and electricity are to be available on location. Water will be hauled to the site. Electricity can be supplied by rented generators. An all-weather road will be maintained to allow access to the injection well and related facilities. The location will be lined with an impervious liner and matting boards will be installed to protect the liner.

1. Mobilize the rotary drilling rig and support equipment and rig up on location with appropriate anchoring. Prepare a polyvinyl (16-ounce) liner with berms and drainage sumps. Install the liner as the rig is erected. The liner will be placed under the rig, pumps, and tanks. Rig up a "zero discharge" closed loop solids control system.
2. Drive or auger 16-inch OD x 0.656-inch wall conductor casing to refusal. Have 80 feet of pipe on site.
3. Install a drilling diverter system. Inventory all tubulars (drillpipe and drill collars) on location. Rig up a full service (24 hours/day) mud logger. Rig personnel will catch drill cutting samples every 30 feet, from the surface to total depth.



4. Drill a 12 ¼-inch hole to 1,200 feet with a 12 ¼-inch bottom-hole assembly (BHA) on 4 ½-inch drill pipe. The base of the aquifer below the Corcoran Clay confining unit is at approximately 1,100 feet. Use a drill pipe float and at least one welded blade stabilizer located 60 feet above the bit. Conduct a deviation survey below the conductor casing, every 500 feet, and on trips. Vertical deviation is not to exceed 1° increase from the previous survey or 1° per 1,000 feet of hole. Circulate the hole clean and make a wiper trip to the surface prior to open-hole logging. Measure (strap) the drill pipe. Notify EPA-Region 9 of the logging schedule.

NOTE: Run de-sander, de-silter, and mud cleaners during all drilling. Run the centrifuge as needed. Maintain a mud weight of 9.5 to 9.8 ppg to control wellbore stability and viscosity from 35 to 70 seconds/quart for effective hole cleaning. All cuttings will be contained in steel roll-off boxes and all liquid will be stored in frac tanks for disposal as required.

5. Conduct a surface casing open-hole logging program consisting of:
 1. Spontaneous potential
 2. Induction-resistivity
 3. 6-arm caliper
 4. Neutron/density and gamma ray

Verify the freshwater aquifer associated with the Corcoran Clay. Calculate the surface casing cement volumes and add 50% excess which will be verified by the caliper log.

6. Trip into the hole to circulate and condition the hole prior to running the casing. Trip out of hole. Notify EPA-Region 9 of the casing and cementing schedules.
7. The base of the aquifer below the Corcoran Clay confining unit is at approximately 1,100 feet. To isolate the base of this aquifer, run 1,200 feet of 8 ⅝-inch, 25 lb/ft, J-55 ST&C casing equipped with a float shoe on the bottom and a float collar one joint off the bottom. Centralizers will be installed near the float shoe, at the center of the first joint, near the float collar, on the collars of the second and third joints, and on every third collar thereafter, or where applicable.
8. Establish circulation and circulate at least one casing volume of drilling fluid. Monitor drilling fluid properties and circulate until the properties are similar to the expected cement slurry properties. Cement the 8 ⅝-inch casing and circulate the cement back to the surface. The slurry will consist of light-weight lead cement and a final slurry of standard, premium cement. Displace the wiper plug to the float collar. Assure that the floats are holding by checking for flow back.
9. Center the casing in the rotary table, drain and flush the diverter stack but do not move the casing for a minimum of 24 hours. Conduct a temperature survey approximately 6 to 8 hours after displacing the plug to locate the top of cement. If the cement does not stand at the surface, bring it to the surface utilizing a tremie line.
10. After 24 hours, nipple down the diverter system and cut the 16-inch conductor. Dress the 8 ⅝-inch casing and install an 8 ⅝-inch swedge to 10 ¾-inch and a 10 ¾-inch x 11-inch, 3000-psi WP casing head assembly. Plate and weld



the 16-inch casing into the 8 5/8-inch casing. Install the 11-inch, 3000-psi WP (minimum) blowout preventers, choke manifold, and flow lines. Set a test plug and pressure test the BOP stack to specifications.

11. Wait on cement to cure for a minimum of 24 hours after plug down. Run a cement bond log on the 8 5/8-inch casing. Trip in the hole with a 8 5/8-inch bit, stabilizer, and drill collars to the top of the plug. Pressure test the surface casing to 1,000 psi according to the most recent guidelines of EPA-Region 9. Notify EPA-Region 9 of the test at least 24 hours prior to testing.
12. Drill out the plug, float collar, shoe joint, and float shoe. Conduct a Formation Integrity/Shoe Test to an equivalent pressure of 10.5 lb/gal drilling fluid for 30 minutes.
13. Drill a 7 7/8-inch hole to 3,600 ft.

NOTE: From the base of surface casing to total depth, maintain mud weight from 9.6 to 9.9 ppg for wellbore stability and maintain plastic viscosity as needed for hole cleaning.

14. When the total depth of the well is reached, circulate and make a short trip to condition the hole for logging. Trip out of the hole, strapping the drillpipe. Notify EPA-Region 9 of the logging schedule.
15. Conduct the long-string casing open-hole logging program consisting of:
 1. Spontaneous potential
 2. Gamma ray
 3. Resistivity
 4. Caliper
 5. Compensated neutron/lithodensity

The surveys will be run from total depth to 1,200 feet. Calculate long-string cement volumes plus 20% excess according to the cement stage collar placement intervals. Use 50% excess in areas where the caliper cannot measure the hole diameter.

16. Take several formation fluid samples within the following intervals: 1,810 to 1,845 feet KB; 1,930 to 1,965 feet KB; 2,040 to 2,120 feet KB; and 3,401 to 3,460 feet KB (according to the electric log of AP-1). The exact formation sampling depths will be confirmed from the open hole logs. The formation fluid samples at these depths will determine the baseline water samples to be compared to future sampling. Take sidewall cores after the formation fluid samples are retrieved.

NOTE: Sidewall cores may be taken in the Confining Zone (between approximately 3,250 to 3,401 feet KB) and Injection Zone Monitoring Interval (between approximately 3,401 to 3,460 feet KB). Sidewall cores may be necessary for acquiring porosity and permeability data to improve the ZEI calculations for the WD-3 permit.

17. Trip into the hole to circulate and condition the hole prior to running the casing. Notify EPA-Region 9 of the casing and cementing schedules. Trip out of hole laying down the 4 1/2-inch drillpipe.
18. Run 5 1/2-inch, 17.0 lb/ft, J-55, LT&C casing from total depth to the surface, with a float shoe on the bottom and a float collar one joint off the bottom. Centralizers will be installed between the float shoe and the float collar at the



center of the shoe joint, on the center of the first joint, on the collars of the first and second joints, and on every third collar thereafter, or where applicable.

19. Cement the 5 ½-inch casing back to the surface with a lead lightweight cement followed by a higher density (14 ppg) tail cement.

NOTE: Cement details will be confirmed at a later date.

20. Conduct a temperature survey approximately 8 hours after displacing the plug. If the cement does not stand at the surface, bring it up to the surface utilizing a tremie line.
21. Nipple down the blowout preventer equipment and casing head. Plate and weld the 5 ½-inch casing out to the 10 ¾-inch casing. Cut off and dress the 5 ½-inch casing and install the 5 ½-inch x 8 ⅝-inch top, 3000-psi, slip-on-weld casing head with two 2-inch, 3000-psi side outlets with two 2-inch ball valves. Install a blind flange on top. A generic wellhead schematic is included in Figure 4-4 of the Monitoring Well Plan.
22. Release the drilling rig, rig down the drilling rig, and move off site or to the second well.
23. Dispose of all excess drilling fluids and solids prior to moving in a completion unit.
24. Move in and rig up a wireline unit and run:
 1. A cement bond/variable density log.
 2. baseline temperature survey.
 3. Rig down wireline unit.
25. Trip in hole with 2 ⅞-inch PH-6 workstring and conduct the final long-string casing pressure test. Test the casing to 1,600 psi minimum for 30 minutes or to the most recent EPA-Region 9 guidelines for mechanical integrity testing. Notify EPA-Region 9 at least 24 hours in advance of the pressure test.
26. Rig up the wireline unit and perforate the selected interval(s), as determined from the open-hole logs, with one jet shot per foot.
27. Obtain an initial bottom-hole pressure measurement at the top of the perforations.
28. Pull out of hole and rig down and move out the wireline unit.
29. The sampling of the formation fluid will be conducted while backflowing the perforations with nitrogen.
30. Run a retrievable test packer on a 2 ⅞-inch work string and set the packer at the bottom of the 5 ½-inch casing.
31. Swab the formation until a representative sample (use mud balance to measure density, use tool to measure TDS content) of the formation is retrieved and the influx of sand is minimal.
32. Remove the packer and run the work string (if necessary), to circulate sand fill out of the casing. Evaluate the sand returns and determine if a slotted liner is required to stabilize sand influx while monitoring the injection interval of WD-3.



33. If required, using the work string, install a 2 7/8-inch, steel liner with 0.020" slots inside the casing to the uppermost perforation depth. Run a stainless steel polished hookup nipple at the top of the liner. Gravel pack the liner with 16-30 mesh gravel (mesh size will be confirmed with a sample of formation sand) pack sand. Release from the liner and pull the gravel pack equipment.
34. Install the injection packer and run 2 7/8-inch injection tubing with pressure-temperature gauge. Subsequently stab the seal assembly section into packer. Pressure test casing to 500 psi for 30 minutes.
35. Land the tubing in the 3,000 psi WP wellhead with casing head slips and top nut and install the wellhead upper 3,000 psi WP section on the 2 7/8-inch injection tubing.
36. Conduct a 30-minute annulus pressure test to 100 psi above the maximum permitted pressure or as required by EPA-Region 9.
37. Nipple up the 3,000 psi WP wellhead and torque all bolts to the specified optimum torque values.
38. Rig down the workover unit and all ancillary equipment and move off location.
39. A monitor wellbore schematic is presented as Figure 4-1 of the Monitoring Well Plan.
40. A schematic of the 5 1/2-inch by 2 7/8-inch packer and seal assembly are included as Figure 4-3 of the Monitoring Well Plan.
41. A wellhead schematic is presented as Figure 4-4 of the Monitoring Well Plan.
42. The permanent downhole gauge information is presented in Appendix D of the Monitoring Well Plan.
43. Turn MW-1D over to HCC for monitoring operations.

9. Contingency Plans for Lost Circulation, Over-Pressured Zones, and Stuck Pipe

The immediate area has no history of lost circulation. No over-pressured zones are known to be present above the proposed total depth of the well. However, should lost-circulation or over-pressured zones be encountered, the following contingency plans will apply:

1. Lost circulation:

Lost circulation is the most common problem in drilling. The normal range of lost-circulation problems begins in shallow unconsolidated sands and extends to the well-consolidated formations that are fractured by the hydrostatic pressure imposed by the drilling fluid. In the shallow, unconsolidated surface formations, the drilling fluid may flow freely into the formation because of its high permeability. Drilling may continue without circulation, or the mud may be thickened to slow the rate of loss.

A general solution to lost circulation below the surface casing in normally pressured formations is to drill without fluid returns to the surface. This practice requires large volumes of water and close supervision. In principle, the generated cuttings are removed from the bottom and deposited in the lost-circulation zone. Specific problems in this part of the hole that may require attention include seepage losses, a complete loss of circulation where there is a requirement for obtaining cuttings back to the surface for formation evaluation purposes, and areas that have a



serious limitation on the available water supply. To prevent these problems, a fine or coarse lost-circulation material may be used to reduce the rate of loss. In general, the lost-circulation material is used in the entire mud system for this type loss. Other options to control lost circulation include setting cement plugs or utilizing an aerated fluid column or a viscous foam. The appropriate method that will be applied will be determined by the drilling equipment available, actual downhole conditions, and wellsite experience (Moore, 1974).

2. Over-Pressured Zones

No over-pressured zones are known to occur in the immediate area. However, over-pressured zones can be controlled by maintaining the proper weighted mud column on the formation. A blowout occurs when the encountered formation pressure exceeds the mud column pressure, which allows the formation fluids to blow out of the hole. Proper mud density is the principal factor in avoiding this problem; however, borehole pressure reductions below mud column pressures are in many instances caused by too rapid withdrawal of the drill string. This is known as pipe pulling suction (swabbing) and has become recognized as a large factor promoting blowouts. This is particularly true in areas where a very delicate overbalance of formation pressure is necessary. The magnitude of the pulling suction depends on the speed of pipe withdrawal, the clearance between the hole and the pipe, and mud viscosity and gel strength. This is a further argument for keeping mud viscosity at a minimum (Gatlin, 1961).

3. Stuck Pipe

Stuck pipe can be caused by key-seating, an accumulation of cuttings around the pipe or balling up of the bit, and pipe being stuck in the filter cake. Key-seating is still recognized as a primary reason for sticking pipe. One recommendation for preventing this problem has been to keep the hole straight. This is recognized as a possible solution, but emphasis is placed on controlling rate of deviation and sudden changes in hole direction. Methods that can be used to free pipe from a key seat include:

1. A jarring action.
2. Spotting of oil to reduce friction.
3. Pipe rotation.

Hole cavings and cuttings that accumulate in cavities offer potential hazards to sticking pipe. Suggested methods for freeing pipe include:

1. If circulation is not possible, shut off the pump and release the pressure, then work the pipe slowly.
2. If circulation is possible but limited, circulate clear water to help remove cuttings from around the pipe.
3. If Step 2 is unsuccessful, spot oil around the pipe to reduce friction. (Moore, 1974).

Pipe being stuck in the filter cake is known as differential pressure sticking. Again, to control differential sticking, the mud properties must be closely monitored so that a thick wall cake is not produced.

10. REFERENCES

- Moore, P.L., 1974, Drilling Practices Manual: Petroleum Publication Co., Tulsa, 301 pages.
- Gatlin, C., 1961, Some Effects of Size Distribution on Particle Bridging in Lost Circulation and Filtration: Trans. SPE Vol. 222, p. 575.

**TABLE 4-1
Tubular Minimum Design Factors
5-1/2-inch, Protection Casing**

Collapse Safety Factor	1.125
Tensile Safety Factor	1.6
Burst Safety Factor	1
Depth	3550
Outside Diameter	5.5
Weight	17
Collapse Requirement	1,313
Tensile Requirement	87,171
Burst Requirement	1,167
Collapse Safety Factor	3.74
Tensile Safety Factor	2.63
Burst Safety Factor	4.56

Annular Fluid Weight (ppg)	14.65
Casing Fluid Weight (ppg)	8.33

Possible Drill Strings					
Outside Diameter	Grade	Weight	Collapse Yield	Tensile Yield	Burst Yield
5.5	F-25	13	1660	94000	1810
5.5	H-40	14	2630	130000	3110
5.5	J-55	14	3120	172000	4270
5.5	J-55	15.5	4040	202000	4810
5.5	J-55	17	4910	229000	5320
5.5	K-55	14	3120	189000	4270
5.5	K-55	15.5	4040	222000	4810
5.5	K-55	17	4910	252000	5320
5.5	C-75	17	6070	327000	7250
5.5	C-75	20	8440	403000	8430
5.5	C-75	23	10460	473000	8430
5.5	C-75	26	11860	432000	
5.5	N-80	17	6280	348000	7740
5.5	N-80	20	8830	428000	8990
5.5	N-80	23	11160	502000	8990
5.5	N-80	26	12650	315000	
5.5	C-95	17	6930	374000	9190
5.5	C-95	20	10000	460000	10680
5.5	C-95	23	12920	540000	10680
5.5	C-95	26	15020		
5.5	P-110	17	7460	445000	10640
5.5	P-110	20	11080	548000	12360
5.5	P-110	23	14520	643000	12360
5.5	P-110	26	17390	393000	
5.5	V-150	20	13480	701000	16860
5.5	V-150	23	18390	823000	16860
5.5	V-150	26	23720		22720

TABLE 4-1 (Continued)
Tubular Minimum Design Factors
8.625-inch, Surface Casing

Collapse Safety Factor	1.125
Tensile Safety Factor	1.6
Burst Safety Factor	1
Depth	1200
Outside Diameter	8.625
Weight	24
Collapse Requirement	444
Tensile Requirement	41,600
Burst Requirement	394
Collapse Safety Factor	3.09
Tensile Safety Factor	5.87
Burst Safety Factor	7.48

Annular Fluid Weight (ppg)	14.65
Casing Fluid Weight (ppg)	8.33

Possible Drill Strings					
Outside Diameter	Grade	Weight	Collapse Yield	Tensile Yield	Burst Yield
8.625	F-25	24	950	161000	1340
8.625	H-40	28	1640	233000	2470
8.625	H-40	32	2210	279000	2860
8.625	J-55	24	1370	244000	2950
8.625	J-55	32	2530	372000	3930
8.625	J-55	36	3450	434000	4460
8.625	K-55	24	1370	263000	2950
8.625	K-55	32	2530	402000	3930
8.625	K-55	36	3450	468000	4460
8.625	C-75	36	4020	648000	6090
8.625	C-75	40	5350	742000	6850
8.625	C-75	44	6680	834000	7610
8.625	C-75	49	8200	939000	8480
8.625	N-80	36	4100	688000	6490
8.625	N-80	40	5520	788000	7300
8.625	N-80	44	6950	887000	8120
8.625	N-80	49	8570	997000	9040
8.625	C-95	36	4360	789000	7710
8.625	C-95	40	6010	904000	8670
8.625	C-95	44	7730	1017000	9640
8.625	C-95	49	9690	1144000	10740
8.625	P-110	40	6380	1055000	10040

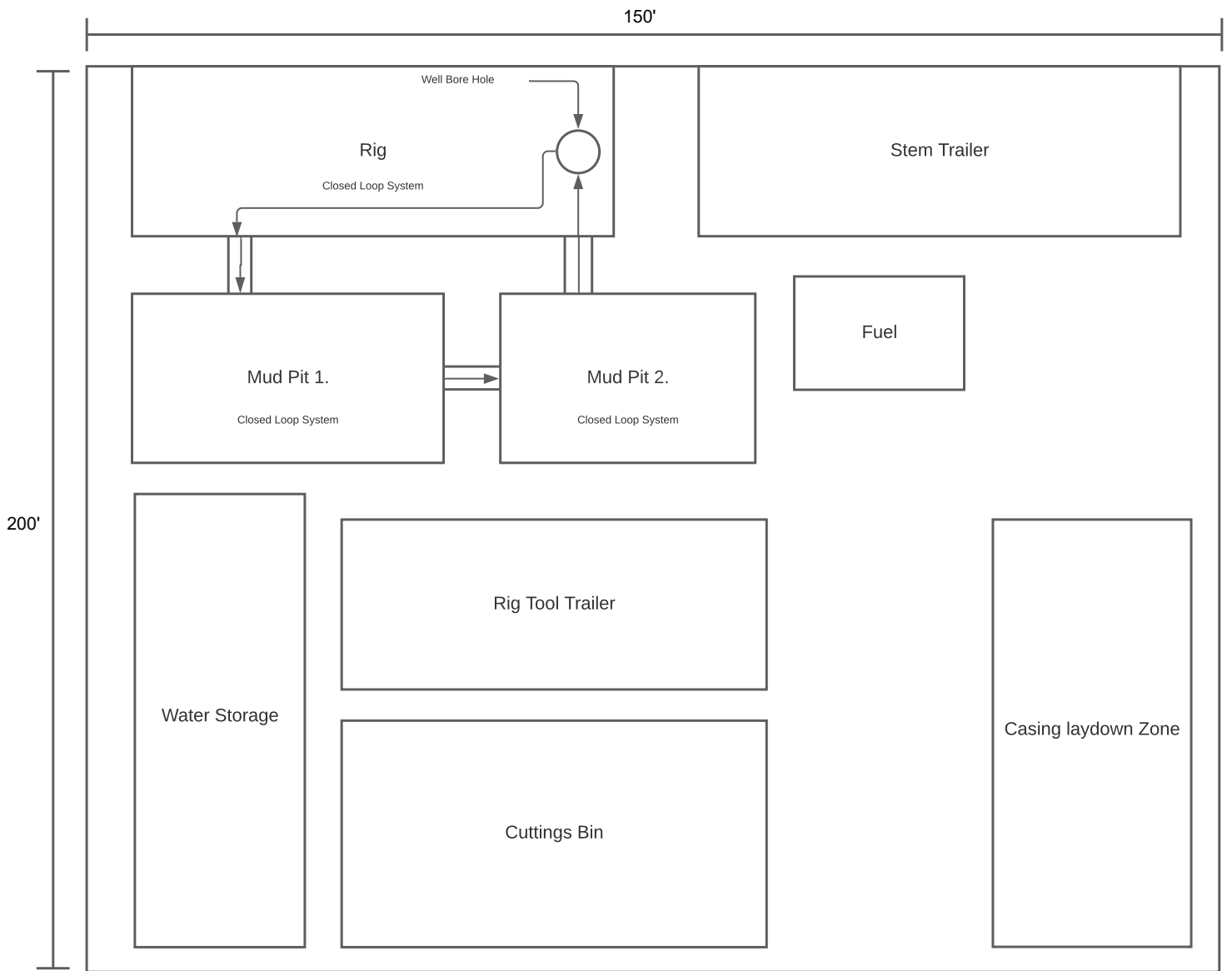

Figure 4-5
MW-1D Rig Footprint

APPENDIX

C

MW-2D DRILLING PLAN



Hilmar Cheese Company
Hilmar, California

Project No. 192024F

Drilling and Completion
Procedure Monitor MW-2D

Date 3/11/2021

Page 1 of 9

Operator: Hilmar Cheese Company
Well: MW-2D Drilled near Plugged Well AP-3
City: Hilmar
County: Merced
State: California

1. Construction Procedure and Objectives

Hilmar Cheese Company (Hilmar) will be applying for a permit to drill monitor well MW-2D. MW-2D will be drilled into the Paleo-Cretaceous sand approximately 520 feet from the abandoned well AP-3 (a map of the location distances between AP-3 and approximately 3,865 feet from WD-3. The Paleo-Cretaceous sand is the sand formation that Hilmar injects into in WD-3.

MW-2D will be used to monitor any pressure buildup and the water quality in the Injection Zone that might be occurring due to injection into WD-3.

MW-2D will subsequently be plugged back to the base of the Underground Source of Drinking Water (USDW). MW-2D will be used to monitor any pressure buildup and the water quality in the USDW that overlies the WD-3 Injection Zone that might be occurring due to injection into WD-3.

The 2 7/8-inch monitoring tubing and packer will be pulled.

Depending on where the Injection Zone from WD-3 intersects MW-2D on the open-hole logs, a cement plug with sand on top will be set above the Injection Zone Monitoring Interval.

The wellbore will be cleaned out to the top of the cement plug and the base of the USDW will be perforated based on the open-hole logs through the USDW Monitoring Interval.

Actions to be taken in case of lost circulation, over-pressured zones and stuck pipe situations are discussed in Section 9 of this Drilling Plan.

2. Detailed Well Construction Procedure

NOTE: The actual depths of where pipe will be set, size of the tubulars, cement additives and weights, and the properties of the drilling mud are estimates only and will be based on the geology of the formations drilled into.

Any significant deviation from the proposed program will require prior approval from the WSP Project Manager and Hilmar Cheese Company.

3. Casing Design

The length and quality of the surface casing is selected and designed to protect the freshwater aquifer associated with the Corcoran Clay. The long string and injection tubing are designed to best suit the existing subsurface formation fluid and injected fluid environment. The long string casing will also protect the base of the USDW. The anticipated life of proposed MD-2, including the wellhead, casings, cement, injection tubing, and packer, is estimated to be 50 years.

PREPARED BY: Larry K. McDonald

REVIEWED BY: Tim Jones

DATE: 3/11/2021
Revision 5



ANTICIPATED TUBULAR PROGRAM

Conductor Casing	0 to ±80 feet	16-inches conductor casing, wall of 0.656 inch augured or driven to refusal (±80 feet)
Surface Casing	0 to 1,200 feet	8 5/8-inch, 24 lb/ft, J-55, ST&C, ID of 8.097 inches
Protection Casing	0 to 3,550 feet	5 1/2-inch, 17.0 lb/ft, J-55, LT&C, ID of 4.892 inches
Monitoring Tubing	0 to 3,250 feet	2 7/8-inch, 6.50 lb/ft, L-80, LT&C, ID of 2.323 inches
Packer	3,250 feet	5 1/2-inch x 2 7/8-inch packer and seal assembly

Minimum Design Factors:

Collapse Strength	1.125
Joint Strength	1.6
Internal Yield Pressure	1.0
Mud Weight	14.65 lb/gal

The details of the tubulars minimum design factors are included in Table 4-1.

All strings of casing and tubing will be certified as new with mill test reports and verification via third party positive material identification (PMI). Carbon steel tubular goods will be inspected with electromagnetic induction testing (Amolog IV or equivalent), with full length drift and special end area evaluations.

All tubular goods will be shipped with thread protectors and loaded onto trucks using wooden stripping between layers.

All tubular goods will be offloaded at the site using a forklift to protect from damage while handling. Threads will be cleaned and new thread compound will be installed prior to installation.

4. Proposed Completion Interval and Completion Type

The proposed monitor well will be completed by:

- Setting the casing through the interval to be monitored, cementing the casing in place, and perforating at the desired depths.
- The perforated interval is estimated to be from 3,401 feet to 3,460 feet KB with a gross interval thickness of approximately 59 feet.

5. Number and Location of Centralizers

On the surface casing, centralizers will be installed near the float shoe, on the collars of the second and third joints, and on every third collar thereafter or where applicable. Wall scratchers will not be used.



On the protection casing, centralizers will be installed between the float shoe and float collar at the center of the joint between the float shoe and float collar, or where applicable. Wall scratchers will not be used.

6. Annulus Fluid

The annulus fluid will be a sodium chloride brine with oxygen scavenger, biocide, and corrosion inhibitor.

7. Logging Program

The anticipated logging program is as follows:

ANTICIPATED LOGGING PROGRAM

Logging Sections	Logging Services	Logging Depth Interval
Surface Hole (12 ¼-inch)	Triple Combo - Spontaneous potential, induction-resistivity, neutron-density and gamma ray, 6-arm caliper	80 to 1,200 feet
Production Hole (7 ⅞-inch)	Triple Combo - Spontaneous potential, induction-resistivity, neutron-density and gamma ray, 6-arm caliper, Compensated neutron/lithodensity	1,200 to 3,600 feet
Cased Hole (8 ⅝-inch surface casing)	Cement bond/variable density log and Temperature survey	0 to 1,200 feet
Cased Hole (5 ½-inch production casing)	Cement bond/variable density log, baseline temperature survey	0 to 3,550 feet

8. Proposed Drilling Plan

The following drilling and completion procedure have been designed for the installation of proposed monitor well MW-2D. A schematic of the rig footprint is included as Figure 4-5.

Survey and prepare the location for all-weather operations. Install an 8-foot diameter corrugated metal pipe cellar by 4 feet deep.

Drilling water and electricity are to be available on location. Water will be hauled to the site. Electricity can be supplied by rented generators. An all-weather road will be maintained to allow access to the injection well and related facilities. The location will be lined with an impervious liner and matting boards will be installed to protect the liner.

- Mobilize the rotary drilling rig and support equipment and rig up on location with appropriate anchoring. Prepare a polyvinyl (16-ounce) liner with berms and drainage sumps. Install the liner as the rig is erected. The liner will be placed under the rig, pumps, and tanks. Rig up a "zero discharge" closed loop solids control system.
- Drive or auger 16-inch OD x 0.656-inch wall conductor casing to refusal. Have 80 feet of pipe on site.
- Install a drilling diverter system. Inventory all tubulars (drillpipe and drill collars) on location. Rig up a full service (24 hours/day) mud logger. Rig personnel will catch drill cutting samples every 30 feet, from the surface to total depth.



4. Drill a 12 ¼-inch hole to 1,200 feet with a 12 ¼-inch bottom-hole assembly (BHA) on 4 ½-inch drillpipe. The base of the aquifer below the Corcoran Clay confining unit is at approximately 1,100 feet. Use a drillpipe float and at least one welded blade stabilizer located 60 feet above the bit. Conduct a deviation survey below the conductor casing, every 500 feet, and on trips. Vertical deviation is not to exceed 1° increase from the previous survey or 1° per 1,000 feet of hole. Circulate the hole clean and make a wiper trip to the surface prior to open-hole logging. Measure (strap) the drillpipe. Notify EPA-Region 9 of the logging schedule.

NOTE: Run de-sander, de-silter, and mud cleaners during all drilling. Run the centrifuge as needed. Maintain a mud weight of 9.5 to 9.8 ppg to control wellbore stability and viscosity from 35 to 70 seconds/quart for effective hole cleaning. All cuttings will be contained in steel roll-off boxes and all liquid will be stored in frac tanks for disposal as required.

5. Conduct a surface casing open-hole logging program consisting of:
 1. Spontaneous potential
 2. Induction-resistivity
 3. 6-arm caliper
 4. Neutron/density and gamma ray

Verify the freshwater aquifer associated with the Corcoran Clay. Calculate the surface casing cement volumes and add 50% excess which will be verified by the caliper log.

6. Trip into the hole to circulate and condition the hole prior to running the casing. Trip out of hole. Notify EPA-Region 9 of the casing and cementing schedules.
7. The base of the aquifer below the Corcoran Clay confining unit is at approximately 1,100 feet. To isolate the base of this aquifer, run 1,200 feet of 8 ⅝-inch, 24 lb/ft, J-55 ST&C casing equipped with a float shoe on the bottom and a float collar one joint off the bottom. Centralizers will be installed near the float shoe, at the center of the first joint, near the float collar, on the collars of the second and third joints, and on every third collar thereafter, or where applicable.
8. Establish circulation and circulate at least one casing volume of drilling fluid. Monitor drilling fluid properties and circulate until the properties are similar to the expected cement slurry properties. Cement the 8 ⅝-inch casing and circulate the cement back to the surface. The slurry will consist of light-weight lead cement and a final slurry of standard, premium cement. Displace the wiper plug to the float collar. Assure that the floats are holding by checking for flow back.
9. Center the casing in the rotary table, drain and flush the diverter stack but do not move the casing for a minimum of 24 hours. Conduct a temperature survey approximately 6 to 8 hours after displacing the plug to locate the top of cement. If the cement does not stand at the surface, bring it up to the surface utilizing a tremie line.
10. After 24 hours, nipple down the diverter system and cut the 16-inch conductor. Dress the 8 ⅝-inch casing and install an 8 ⅝-inch swedge to 10 ¾-inch and a 10 ¾-inch x 11-inch, 3000-psi WP casing head assembly. Plate and weld



the 16-inch casing into the 8 5/8-inch casing. Install the 11-inch, 3000-psi WP (minimum) blowout preventers, choke manifold, and flow lines. Set a test plug and pressure test the BOP stack to specifications.

11. Wait on cement to cure for a minimum of 24 hours after plug down. Run a cement bond log on the 8 5/8-inch casing. Trip in the hole with a 8 5/8-inch bit, stabilizer, and drill collars to the top of the plug. Pressure test the surface casing to 1000 psi according to the most recent guidelines of EPA-Region 9. Notify EPA-Region 9 of the test at least 24 hours prior to testing.
12. Drill out the plug, float collar, shoe joint, and float shoe. Conduct a Formation Integrity/Shoe Test to an equivalent pressure of 10.5 lb/gal drilling fluid for 30 minutes.
13. Drill a 7 7/8-inch hole (with BHA consisting of mud motor and MWD) to 1,250 feet. At 1,250 feet, kickoff building a deviated wellbore such that the MW-2D wellbore is within 100 feet of AP-3 by and vertical near the USDW depth and maintains 100 ft distance from AP-3 through to total depth. (An in-depth directional drilling program will be constructed at a later time.) Continue drilling to 3,600 feet.

NOTE: From the base of surface casing to total depth, maintain mud weight from 9.6 to 9.9 ppg for wellbore stability and maintain plastic viscosity as needed for hole cleaning.

14. When the total depth of the well is reached, circulate and make a short trip to condition the hole for logging. Trip out of the hole, strapping the drillpipe. Notify EPA-Region 9 of the logging schedule.
15. Conduct the long-string casing open-hole logging program consisting of:
 1. Spontaneous potential
 2. Gamma ray
 3. Resistivity
 4. Caliper
 5. Compensated neutron/lithodensity

The surveys will be run from total depth to 1,200 feet. Calculate long-string cement volumes plus 20% excess according to the cement stage collar placement intervals. Use 50% excess in areas where the caliper cannot measure the hole diameter.

16. Take several formation fluid samples within the following intervals: 1,795 to 1,850 feet KB; 1,990 to 2,030 feet KB; 2,075 to 2,135 feet KB; and 3,285 to 3,350 feet KB (according to the electric log of AP-3). The exact formation sampling depths will be confirmed from the real-time gamma ray log and is subject to change. The formation water samples at these depths will determine the baseline water samples to be compared to future sampling. Take sidewall cores after the formation water samples are retrieved.

NOTE: Sidewall cores will be taken in the Confining Zone (between approximately 3,173 to 3,285 feet KB) and Injection Zone Monitoring Interval (between approximately 3,285 to 3,350 feet KB). Sidewall cores are necessary for acquiring porosity and permeability data to improve the ZEI calculations for the WD-3 permit.



17. Trip into the hole to circulate and condition the hole prior to running the casing. Notify EPA-Region 9 of the casing and cementing schedules. Trip out of hole laying down the 4 ½-inch drillpipe.
18. Run 5 ½-inch, 17.0 lb/ft, J-55, LT&C casing from total depth to the surface, with a float shoe on the bottom, and a float collar one joint off the bottom. Centralizers will be installed between the float shoe and the float collar at the center of the shoe joint, on the center of the first joint, on the collars of the first and second joints, and on every third collar thereafter, or where applicable.
19. Cement the 5 ½-inch casing back to the surface with a lead lightweight cement followed by a higher density (14 ppg) tail cement.

NOTE: Cement details will be confirmed at a later date.
20. Conduct a temperature survey approximately 8 hours after displacing the plug. If the cement does not stand at the surface, bring it up to the surface utilizing a tremie line.
21. Nipple down the blowout preventer equipment and casing head. Plate and weld the 5 ½-inch casing out to the 10 ¾-inch casing. Cut off and dress the 5 ½-inch casing and install the 5 ½-inch x 8 ⅝-inch top, 3000-psi, slip-on-weld casing head with two 2-inch, 3000-psi side outlets with two 2-inch ball valves. Install a blind flange on top. A generic wellhead schematic is included in Figure 4-4.
22. Release the drilling rig, rig down the drilling rig, and move off site or to the second well.
23. Dispose of all excess drilling fluids and solids prior to moving in a completion unit.
24. Move in and rig up a wireline unit and run:
 1. A cement bond/variable density log.
 2. baseline temperature survey.
 3. Rig down wireline unit.
25. Trip in hole with 2 ⅞-inch PH-6 workstring and conduct the final long-string casing pressure test. Test the casing to 1,600 psi minimum for 30 minutes or to the most recent EPA-Region 9 guidelines for mechanical integrity testing. Notify EPA-Region 9 at least 24 hours in advance of the pressure test.
26. Rig up the wireline unit and perforate the selected interval(s), as determined from the open-hole logs, with one jet shot per foot.
27. Obtain an initial bottom-hole pressure measurement at the top of the perforations.
28. Pull out of hole and rig down and move out the wireline unit.
29. The sampling of the formation fluid will be conducted while backflowing the perforations with nitrogen.
30. Run a retrievable test packer on a 2 ⅞-inch work string and set the packer at the bottom of the 5 ½-inch casing.
31. Swab the formation until a representative sample (use mud balance to measure density, use tool to measure TDS content) of the formation is retrieved and the influx of sand is minimal.



32. Remove the packer and run the work string (if necessary), to circulate sand fill out of the casing. Evaluate the sand returns and determine if a slotted liner is required to stabilize sand influx while monitoring the injection interval of WD-3.
33. If required, using the work string, install a 2 7/8-inch, steel liner with 0.020" slots inside the casing to the uppermost perforation depth. Run a stainless steel polished hookup nipple at the top of the liner. Gravel pack the liner with 16-30 mesh gravel (mesh size will be confirmed with a sample of formation sand) pack sand. Release from the liner and pull the gravel pack equipment.
34. Install the injection packer and run 2 7/8-inch injection tubing with pressure-temperature gauge. Subsequently stab the seal assembly section into packer. Pressure test casing to 500 psi for 30 minutes.
35. Land the tubing in the 3,000 psi WP wellhead with casing head slips and top nut and install the wellhead upper 3,000 psi WP section on the 2 7/8-inch injection tubing.
36. Conduct a 30-minute annulus pressure test to 100 psi above the maximum permitted pressure or as required by EPA-Region 9.
37. Nipple up the 3,000 psi WP wellhead and torque all bolts to the specified optimum torque values.
38. Rig down the workover unit and all ancillary equipment and move off location.
39. The monitor well schematic is presented as Figure 4-2.
40. The 5 1/2-inch by 2 7/8-inch packer is included as Figure 4-3.
41. A wellhead schematic is presented as Figure 4-4.
42. The permanent downhole gauge information is presented in Appendix E.
43. Turn MW-2D over to Hilmar for monitoring operations.

9. Contingency Plans for Lost Circulation, Over-Pressured Zones, and Stuck Pipe

The immediate area has no history of lost circulation. No over-pressured zones are known to be present above the proposed total depth of the well. However, should lost-circulation or over-pressured zones be encountered, the following contingency plans will apply:

1. Lost circulation:

Lost circulation is the most common problem in drilling. The normal range of lost-circulation problems begins in shallow unconsolidated sands and extends to the well-consolidated formations that are fractured by the hydrostatic pressure imposed by the drilling fluid. In the shallow, unconsolidated surface formations, the drilling fluid may flow freely into the formation because of its high permeability. Drilling may continue without circulation, or the mud may be thickened to slow the rate of loss.

A general solution to lost circulation below the surface casing in normally pressured formations is to drill without fluid returns to the surface. This practice requires large volumes of water and close supervision. In principle, the generated cuttings are removed from the bottom and deposited in the lost-circulation zone. Specific problems in this part of the



hole that may require attention include seepage losses, a complete loss of circulation where there is a requirement for obtaining cuttings back to the surface for formation evaluation purposes, and areas that have a serious limitation on the available water supply. To prevent these problems, a fine or coarse lost-circulation material may be used to reduce the rate of loss. In general, the lost-circulation material is used in the entire mud system for this type loss. Other options to control lost circulation include setting cement plugs or utilizing an aerated fluid column or a viscous foam. The appropriate method that will be applied will be determined by the drilling equipment available, actual downhole conditions, and wellsite experience (Moore, 1974).

2. Over-Pressured Zones

No over-pressured zones are known to occur in the immediate area. However, over-pressured zones can be controlled by maintaining the proper weighted mud column on the formation. A blowout occurs when the encountered formation pressure exceeds the mud column pressure, which allows the formation fluids to blow out of the hole. Proper mud density is the principal factor in avoiding this problem; however, borehole pressure reductions below mud column pressures are in many instances caused by too rapid withdrawal of the drill string. This is known as pipe pulling suction (swabbing) and has become recognized as a large factor promoting blowouts. This is particularly true in areas where a very delicate overbalance of formation pressure is necessary. The magnitude of the pulling suction depends on the speed of pipe withdrawal, the clearance between the hole and the pipe, and mud viscosity and gel strength. This is a further argument for keeping mud viscosity at a minimum (Gatlin, 1961).

3. Stuck Pipe

Stuck pipe can be caused by key-seating, an accumulation of cuttings around the pipe or balling up of the bit, and pipe being stuck in the filter cake. Key-seating is still recognized as a primary reason for sticking pipe. One recommendation for preventing this problem has been to keep the hole straight. This is recognized as a possible solution, but emphasis is placed on controlling rate of deviation and sudden changes in hole direction. Methods that can be used to free pipe from a key seat include:

1. A jarring action.
2. Spotting of oil to reduce friction.
3. Pipe rotation.

Hole cavings and cuttings that accumulate in cavities offer potential hazards to sticking pipe. Suggested methods for freeing pipe include:

1. If circulation is not possible, shut off the pump and release the pressure, then work the pipe slowly.
2. If circulation is possible but limited, circulate clear water to help remove cuttings from around the pipe.
3. If Step 2 is unsuccessful, spot oil around the pipe to reduce friction. (Moore, 1974).

Pipe being stuck in the filter cake is known as differential pressure sticking. Again, to control differential sticking, the mud properties must be closely monitored so that a thick wall cake is not produced.

10. REFERENCES

- Moore, P.L., 1974, Drilling Practices Manual: Petroleum Publication Co., Tulsa, 301 pages.



Hilmar Cheese Company
Hilmar, California

Project No. 192024F

Drilling and Completion
Procedure Monitor MW-2D

Date 3/11/2021

Page 9 of 9

— Gatlin, C., 1961, Some Effects of Size Distribution on Particle Bridging in Lost Circulation and Filtration: Trans. SPE Vol. 222, p. 575.

**TABLE 4-1
Tubular Minimum Design Factors
5-1/2-inch, Protection Casing**

Collapse Safety Factor	1.125
Tensile Safety Factor	1.6
Burst Safety Factor	1
Depth	3550
Outside Diameter	5.5
Weight	17
Collapse Requirement	1,313
Tensile Requirement	87,171
Burst Requirement	1,167
Collapse Safety Factor	3.74
Tensile Safety Factor	2.63
Burst Safety Factor	4.56

Annular Fluid Weight (ppg)	14.65
Casing Fluid Weight (ppg)	8.33

Possible Drill Strings					
Outside Diameter	Grade	Weight	Collapse Yield	Tensile Yield	Burst Yield
5.5	F-25	13	1660	94000	1810
5.5	H-40	14	2630	130000	3110
5.5	J-55	14	3120	172000	4270
5.5	J-55	15.5	4040	202000	4810
5.5	J-55	17	4910	229000	5320
5.5	K-55	14	3120	189000	4270
5.5	K-55	15.5	4040	222000	4810
5.5	K-55	17	4910	252000	5320
5.5	C-75	17	6070	327000	7250
5.5	C-75	20	8440	403000	8430
5.5	C-75	23	10460	473000	8430
5.5	C-75	26	11860	432000	
5.5	N-80	17	6280	348000	7740
5.5	N-80	20	8830	428000	8990
5.5	N-80	23	11160	502000	8990
5.5	N-80	26	12650	315000	
5.5	C-95	17	6930	374000	9190
5.5	C-95	20	10000	460000	10680
5.5	C-95	23	12920	540000	10680
5.5	C-95	26	15020		
5.5	P-110	17	7460	445000	10640
5.5	P-110	20	11080	548000	12360
5.5	P-110	23	14520	643000	12360
5.5	P-110	26	17390	393000	
5.5	V-150	20	13480	701000	16860
5.5	V-150	23	18390	823000	16860
5.5	V-150	26	23720		22720

TABLE 4-1 (Continued)
Tubular Minimum Design Factors
8.625-inch, Surface Casing

Collapse Safety Factor	1.125
Tensile Safety Factor	1.6
Burst Safety Factor	1
Depth	1200
Outside Diameter	8.625
Weight	24
Collapse Requirement	444
Tensile Requirement	41,600
Burst Requirement	394
Collapse Safety Factor	3.09
Tensile Safety Factor	5.87
Burst Safety Factor	7.48

Annular Fluid Weight (ppg)	14.65
Casing Fluid Weight (ppg)	8.33

Possible Drill Strings					
Outside Diameter	Grade	Weight	Collapse Yield	Tensile Yield	Burst Yield
8.625	F-25	24	950	161000	1340
8.625	H-40	28	1640	233000	2470
8.625	H-40	32	2210	279000	2860
8.625	J-55	24	1370	244000	2950
8.625	J-55	32	2530	372000	3930
8.625	J-55	36	3450	434000	4460
8.625	K-55	24	1370	263000	2950
8.625	K-55	32	2530	402000	3930
8.625	K-55	36	3450	468000	4460
8.625	C-75	36	4020	648000	6090
8.625	C-75	40	5350	742000	6850
8.625	C-75	44	6680	834000	7610
8.625	C-75	49	8200	939000	8480
8.625	N-80	36	4100	688000	6490
8.625	N-80	40	5520	788000	7300
8.625	N-80	44	6950	887000	8120
8.625	N-80	49	8570	997000	9040
8.625	C-95	36	4360	789000	7710
8.625	C-95	40	6010	904000	8670
8.625	C-95	44	7730	1017000	9640
8.625	C-95	49	9690	1144000	10740
8.625	P-110	40	6380	1055000	10040

200'

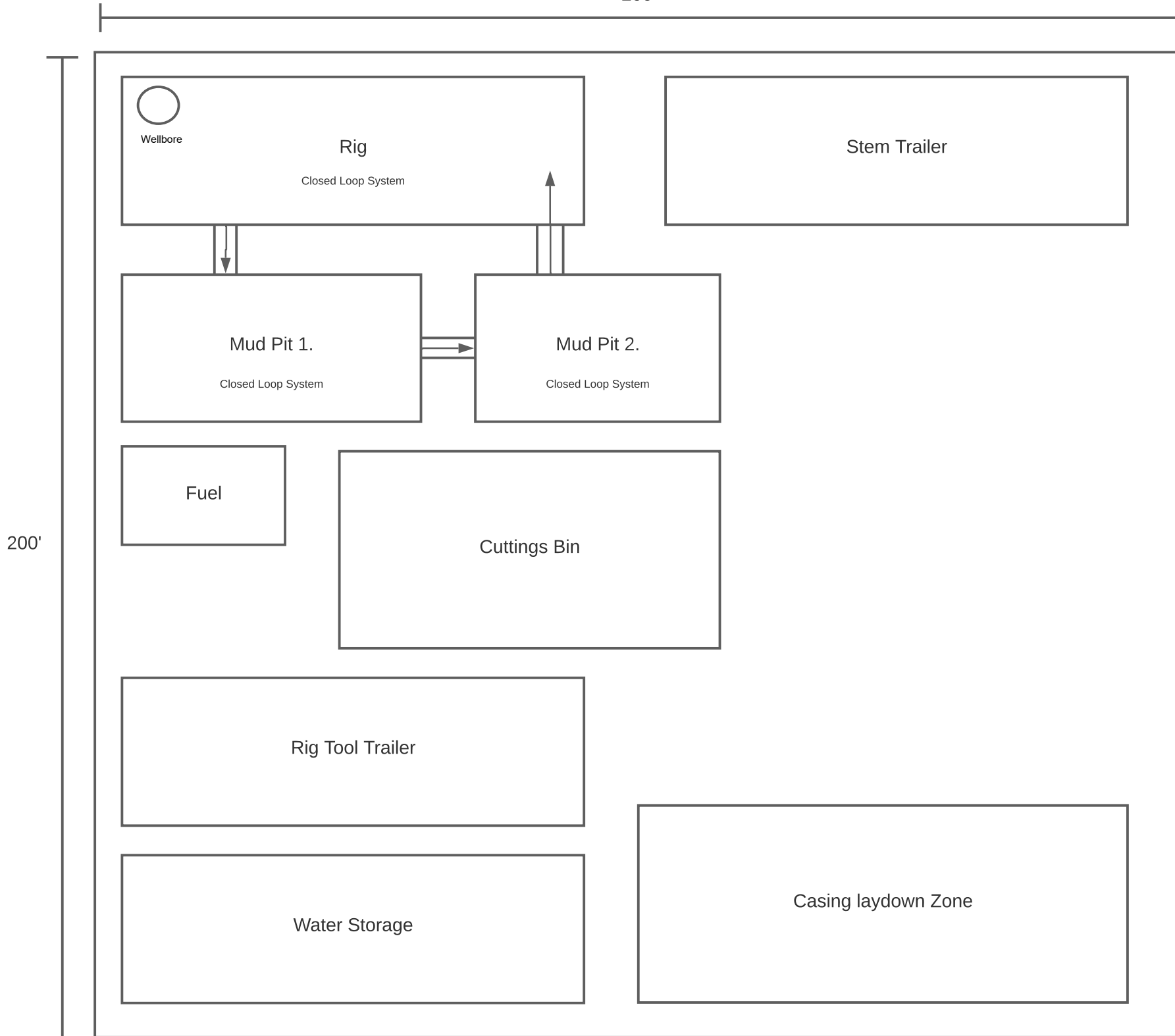

**Figure 4-5
MW-2D Rig Footprint**

APPENDIX

D

DOWNHOLE GAUGE DATA SHEET & DEPLOYMENT

RANGER

GAUGE SYSTEMS

Downhole Single Digital Quartz Pressure/Temperature Probe

3/4" O.D. Ranger Permanent Hybrid Digital Addressable Surface Read Out (DASRO) Gauge

The Ranger® 42xx model gauge is a Quartz Digital Addressable Surface Read Out Pressure/Temperature Probe, similar to the 62xx models and is based on a resonating quartz sensor with digital signal transmission and addressing ability for multiple gauge deployment, on a single line. These units have been redesigned with a reduced diameter. This gauge model provides savings on gauge carrier size and will be able to be deployed in restricted spaces. The internal gauge electronics consists of one custom package microelectronic circuit that is hermetically sealed. Each gauge has a pre-assigned digital addresses for multiple unit operation on the same signal conductor.

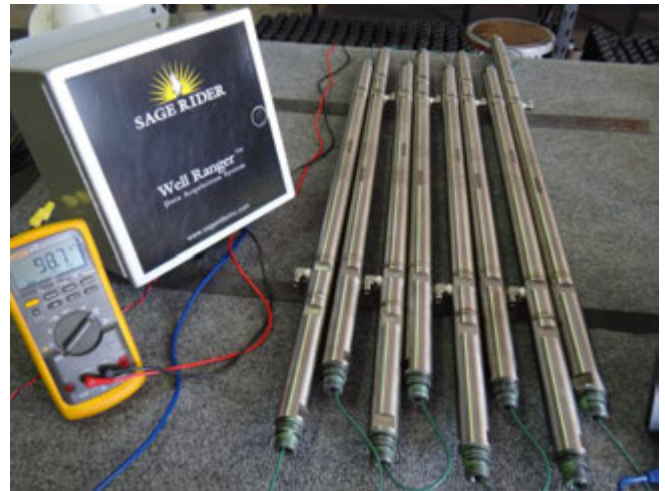

FEATURES

- Single Cable-head with extended nut for clamping purpose
- Leak-testable cable-head
- Fully sealable pressure test port
- Bottom pressure inlet
- No CPU or memory for reliable, long term, high temperature operation. Configuration data and addresses are permanent
- High reliability and quality due to hermetically sealed custom hybrid circuits. This type of circuit construction is a **MUST** for sustained, high-temperature operation
- Hybrid circuits are fully tested and qualified per MIL-883E, Method 1010.7 Test Condition B
- Includes level two reliability testing to yield long operating life required for permanent applications
- Metal to metal seals, ferrules compression pressure fittings and welded Inconel 718® housing construction throughout results in no elastomers
- Inconel 718 pressure housings are standard
- Integral quartz temperature sensor
- Pre-assigned address for multiple unit operation on the same single conductor
- 1024 address capability assures that gauges will have unique addresses
- Low power consumption 500mW (typical)

Specifications

Ranger DASRO gauge specifications are determined in accordance with the ANSI/ISA-S51.1-1979, American National Standard, "Process Instrumentation Terminology".

Pressure Sensor

Thickness shear mode quartz resonator (with INCONEL[®] isolation bellows)

Total System Pressure Accuracy

±0.025% of full scale including linearity, hysteresis and repeatability over calibrated temperature range

Pressure Repeatability

≤0.01% of full scale

Pressure Resolution

0.01 psi or better

Temperature Sensor

Quartz resonator

Temperature Accuracy

±0.5°C (±0.9°F) within calibrated temperature range. Pressure accuracy is independent of indicated temperature accuracy.

Temperature Resolution

0.005°C (0.01°F)

Standard Calibrated Temperature Ranges

25°C to 125°C (77°F to 257°F)

25°C to 150°C (77°F to 302°F)

25°C to 175°C (77°F to 347°F)

25°C to 200°C (77°F to 392°F)

Reliability Testing Levels

- Level II (Basic for all units)
 - 20°C Test to confirm fully and correct operation
 - Calibration and testing to full temperature and pressure ratings
 - 15-day burn-in at full pressure and temperature calibrated ranges
 - Gauge shock and vibration testing
 - Final QC inspection
- Level III (OPTIONAL, Includes Level II)
 - Additional: 15-day burn-in at full pressure and temperature calibrated ranges

DASRO Configurations / Model Numbers

Dual Cable Head SIDE pressure inlet

Single Cable Head SIDE pressure inlet

Single Cable Head BOTTOM pressure inlet

Dual Gauge Dual Cable Head SIDE pressure inlets (two)

Dual Gauge Single Cable Head SIDE pressure inlets (two)

Single FOT Cable Head BOTTOM pressure inlet

Single Cable Head ¾" OD BOTTOM pressure inlet

Dual Cable Head 1.00" OD SIDE pressure inlet

Operating Temperature Range

-20°C to 200°C (-4°F to 392°F)

Sample Rate

Complete pressure and temperature transmission, in approximately one-second intervals

Operating and Calibrated Pressure Ranges

20.68 - 344.75 Bars (300 - 5,000 psia)

20.68 - 689.50 Bars (300 - 10,000 psia)

20.68 - 1103.20 Bars (300 - 16,000 psia)

20.68 - 1378.95 Bars (300 - 20,000 psia) - Optional

Dimensions (O.D. x Length)

1.91 cm x 71.12 cm (0.75" x ~28.00")

Weight

1.13 kg (2.50 lbs)

Pressure Housing Wetted Material

Inconel 718[®]

Sensor Wetted Materials

INCONEL[®] 600/625/718

Requirements of Conductor Cable

Single conductor coaxial cable with low conductor resistance. The maximum DC loop resistance is determined by the number of gauges on one line and the surface power supply. Can be up to 500 ohms with a capacitance of up to 1 ufd for a single unit installation and using a 30 volt surface power supply.



(Model No: 68xxD DASRO) – Same length

(Model No: 68x1D DASRO) – Same length

(Model No: 62xxD DASRO) – Shorter

(Model No: 68x2D DASRO) – Longer

(Model No: 68x4D DASRO) – Longer

(Model No: 62x3D DASRO) – Special length

(Model No: 42xxC DASRO) – Shorter

(Model No: 108xxA DASRO)

"x" or "xx" = Denotes calibrated temperature range. Example: A 175C calibrated gauge 68xxB = 6875B, 68x1B = 6871B, 62xxB = 6275B, 68x2B = 6872B, 62x3B = 6273B or 42xxB=4275B

Layout – Gauge Deployed on Tubing above Packer

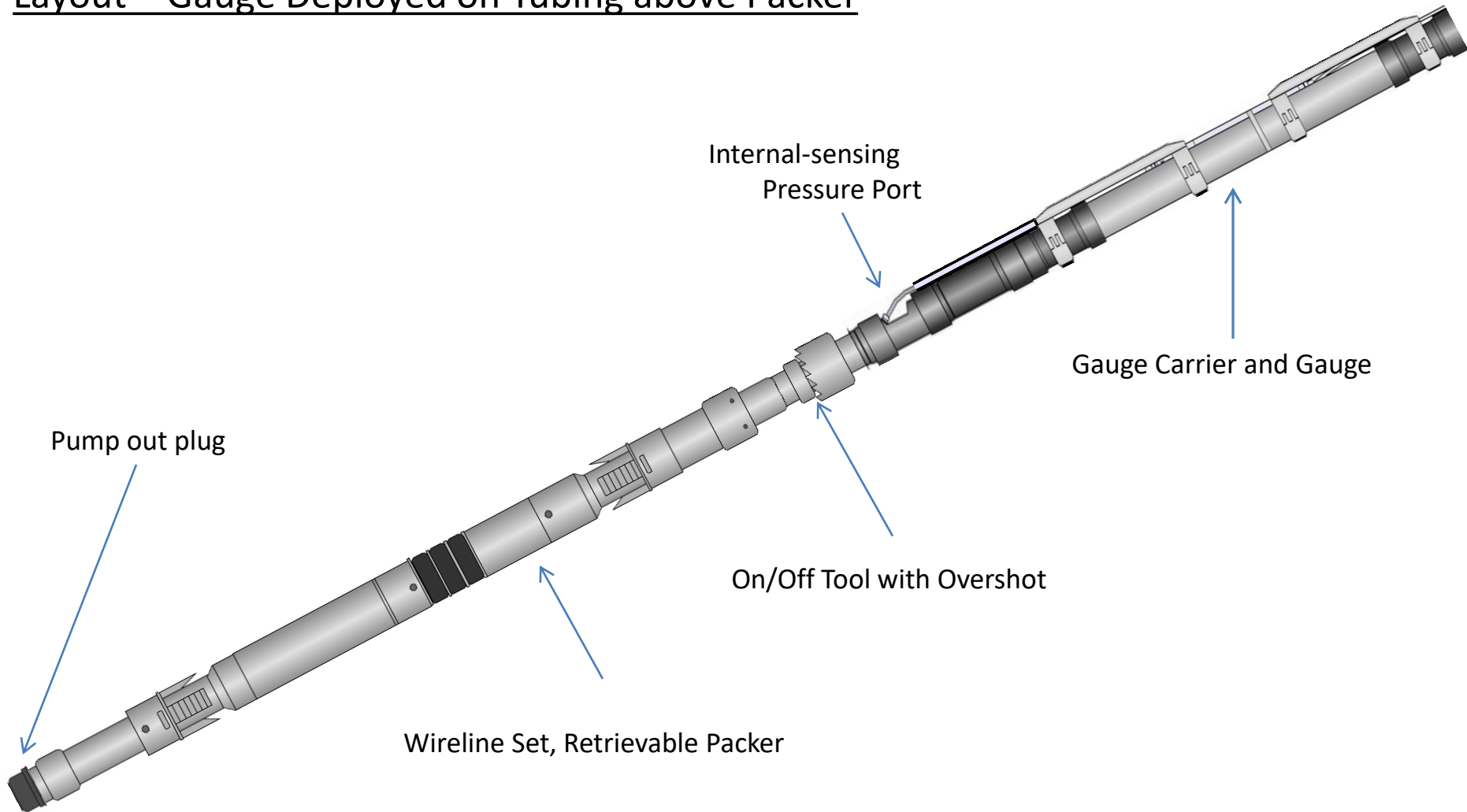

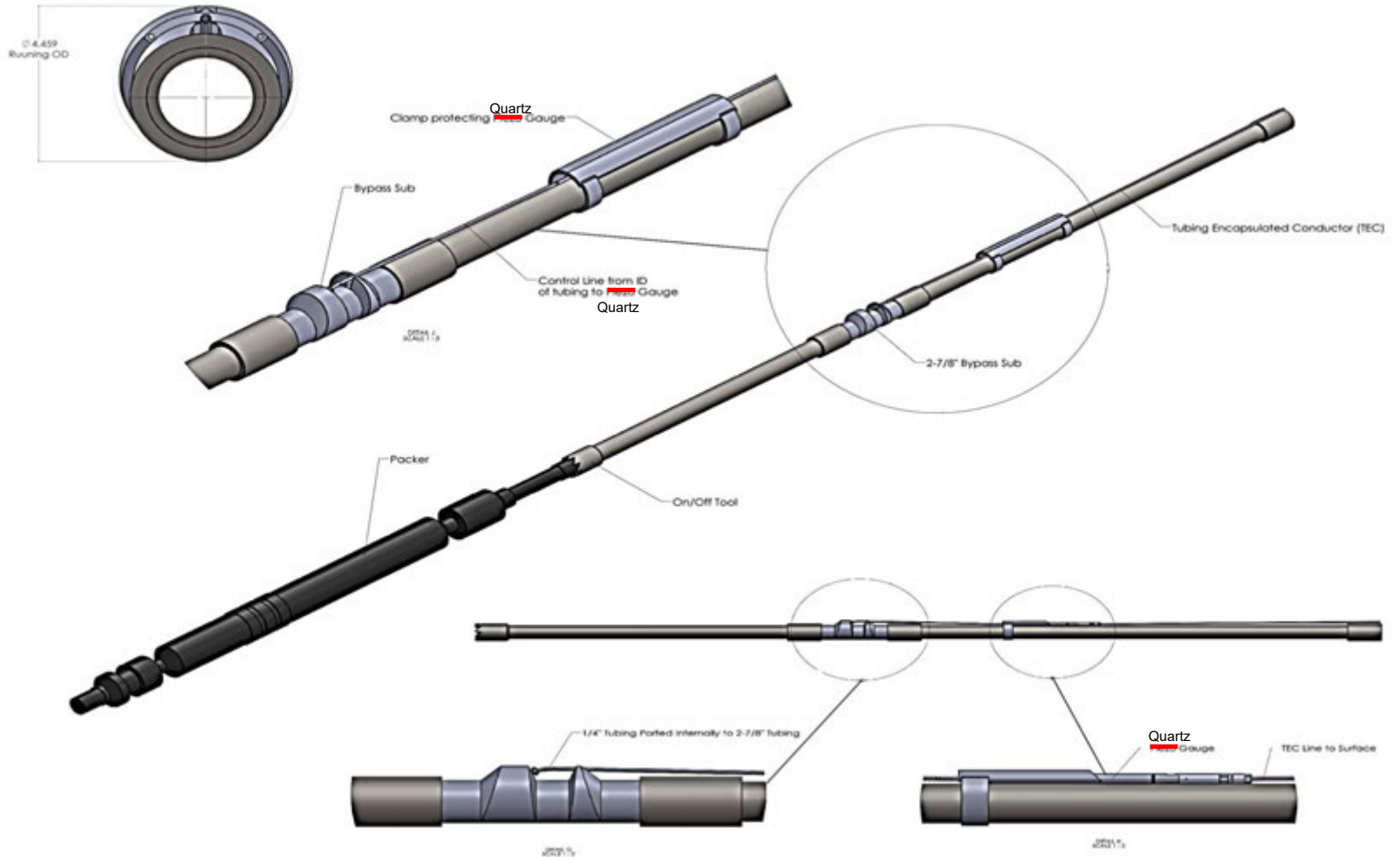

APPENDIX

E

COST ESTIMATE FOR PLUG AND ABANDON

APPENDIX E HILMAR MONITOR WELL CLOSURE COST

Item	Cost
<u>Consultant (see Variables)</u>	
Preclosure and postclosure work	\$15,000
Wellsite @ \$1200/day	\$4,800
<u>Equipment and Services (see Variables)</u>	
Testing & Wireline (APT, MIT, RAT, etc.)	\$29,000
Pressure Falloff (Includes fluids and tanks)	\$0
Workover rig, etc. (Includes rig mob/demob + materials and services)	\$61,804
Mud (\$15/bbl)	\$0
Cement (\$14/sack) (Includes equipment and materials)	\$5,028
Welding	\$1,200
<u>Charge for Hazardous waste well</u>	\$0
Subtotal of Equipment & Services & Hazardous Waste	\$97,032
<u>Consultant Mgmt Fee (10%)</u>	\$9,703
Project Cost Subtotal	\$126,536
<u>Contingency (20%)</u>	\$25,307
Project Cost Total	\$151,843
<u>Financial Assurance Amount</u>	<u>\$152,000</u>

Well Data		
Plugging method (four plugs or cement filled)	1	0-Plugs or 1-Filled
Avg Well Inside Diameter (in)	4.892	
Top of Inj Interval (feet)	3,000	
Plugged Back Total Depth (feet)	3,300	
Hazardous Waste Well	0	0-No or 1-Yes
Calculated Mud Vol (bbl)	0	
Calculated Cement Vol (ft3)	431	

APPENDIX I

WD-2 Step Rate Test Report

UIC Permit R9UIC-CA1-FY15-2R

October 17, 2006

Mr. Eric Byous
U.S. Environmental Protection Agency
Ground Water Office (WTR-9)
75 Hawthorne Street
San Francisco, CA 94105

Subject: **WD #2 Step Rate Test Results; UIC Permit No. CA10500001**
Hilmar Cheese Company

Dear Mr. Byous:

A Step Rate Test (SRT) was conducted on 10-3-06 at WD #2 to determine the fracture pressure of the receiving formation. EPA representatives Eric Byous and George Robin witnessed the test. Digital quartz gauges recorded pressure and temperature at the top effective perforation located at a depth of 3,320'. Surface digital gauges recorded surface pressure and injection rate at the wellhead. Complete data sets from these devices accompany this report, as do spreadsheet summaries and analysis of the data sets.

Prior to starting the test, a successful MIT of the casing annulus was performed to a surface pressure of 1,980 psig.

Test results are summarized as follows:

1. The digital quartz gauge (DQG) recorded atmospheric pressure of 14.3 psia, and when positioned in the injection tree at the surface recorded a static pressure at surface of 50 psia.
2. When run to the top effective perforation @ 3,320', the DQG recorded a static bottom hole pressure of 1502 psia. This calculates to a static pressure gradient of 0.437 psia/ft for fluid standing in the well, or a fluid specific gravity of 1.01.
3. The digital surface pressure gauge recorded 0 psig atmospheric pressure, and 39 psig when exposed to static wellhead pressure at the surface. Applying the 14.3 psi atmospheric pressure recorded by the DQG, the 39 psig static pressure recorded by the digital surface pressure gauge equals 53.3 psia, and is within 6.6% of the value recorded by the DQG. The agreement between the DQG and the digital surface pressure recorder were therefore deemed more than acceptable for acquiring sufficiently accurate data to conduct the SRT.
4. The attached data show the DQG measurements clearly established fracture pressure by diverged pressure slopes plotted against injection rates @ 7.5-17.7 BPM and 20.2-21.6 BPM. The trend lines intersect at a fracture point of 2,730 psia, 18.5 BPM. At the measurement depth of 3,320', this yields a fracture gradient of 0.82 psia/ft.
5. Attached analysis demonstrates observed surface pressure of 1702 psig (interpolated between immediate pre and post frac measurements), and an observed friction pressure (interpolated) of 438 psia.
6. It is noted that the observed friction pressure is ~53% greater than would be indicated by friction pressure calculations. This appears to be due to un-modeled friction pressure through

the injection tree, reduced ID through the packer seal assembly, and presumably by the higher friction coefficient of the Injectate compared to the similarly dense but particle-free fluid used in the friction model. It is further noted that, as friction must increase as the system ages and roughens; use of the presently observed friction numbers remains a conservative method of estimating life cycle friction.

7. Based on the maximum allowable injection pressure value corresponding to 80% of the observed fracture pressure; the above analysis and attached data calculate a maximum allowable injection pressure of 2,184 psia, which interpolation shows occurred at an injection rate of 12.7 BPD during the SRT.
8. Based on the observed (interpolated) surface and friction pressure at 12.7 BPM during the SRT, the maximum allowable surface injection pressure is 919 psig (933 psia); interpolated friction pressure at this rate is 200 psi.

Based on the attached data and analysis, Hilmar Cheese Company requests a maximum surface injection pressure of 919 psig for WD #2, and a maximum injection gradient of 0.658 psia/ft, subject to observed friction pressure correction at existing well conditions.

Please feel free to call or e-mail me with any questions or comments regarding this submittal.

Sincerely,



Barry Hanson
Scavenger Petroleum Services, Inc.

Phone: 661 703-1831
E-mail: barry@jpoil.com

Time	Meter BPM	Surface PSIG	Surface PSIA	Downhole PSIA	Zero Flow ¹ Downhole PSIA	Observed Friction PSIA ²	Estimated Friction BJ tables ³
14:45	0	39	53	1502	1502.0	0.0	0.0
15:23	3.1	97	111	1540	1562.1	22.1	10.4
15:27	5	165	179	1592	1630.1	38.1	24.5
16:25	7.5	316	330	1707	1781.1	74.1	50.9
16:54	9.2	486	500	1844	1951.1	107.1	73.5
17:24	11.5	739	753	2040	2204.1	164.1	110.1
17:55	13.4	1019	1033	2264	2484.1	220.1	145.2
18:25	16	1324	1338	2484	2789.1	305.1	200.2
18:55	17.7	1575	1589	2673	3040.1	367.1	240.6
19:25	20.2	1765	1779	2758	3230.1	472.1	306.0
19:55	21.6	1881	1895	2798	3346.1	548.1	345.7

1. Zero Flow PSIA based on observed pressure gradient of 0.437 psi/ft @ 3320' before pumping starts.
2. Observed friction = Zero Flow PSIA - Downhole PSIA recorded by digital pressure bomb @ 3320'.
3. Friction estimated for 2% KCl (1.01 SPGR) through 3320' of 5" 18# tubing.

Based on fracture pressure = 2730 psi @ 3320'; 80% of fracture pressure = 2184 psia. Interpolated surface pressure @ 2184 psia downhole pressure = 919 psig (933 psia), and friction pressure = 200 psi.

Hilmar WD #2 Step Rate Test, 10-3-06
 Digital Recorder hung @ 3,320'
 2" X 200M, 24R 6°C Slots @ 3,259-4,148'

End Points plotted for Each Stage!

Time	Surface PSIG	Surface PSIA	Downhole PSIA	Meter BPM	BHT	Injec tion Gradient	Remarks
14:45	39	53		1502	0	99	0.452
15:23	97	111	1540	3.1	90	0.464	Start of Test
15:27	165	179	1592	5	88.5	0.480	
16:25	316	330	1707	7.5	88	0.514	
16:54	486	500	1844	9.2	88.7	0.555	
17:24	739	753	2040	11.5	89.6	0.614	
17:55	1019	1033	2264	13.4	90.3	0.682	
18:25	1324	1338	2484	16	90.7	0.748	
18:55	1575	1589	2673	17.7	91	0.805	
19:25	1765	1779	2758	20.2	91.2	0.831	
19:55	1881	1895	2798	21.6	91.3	0.843	

Time	Surface PSIG	Surface PSIA	Downhole PSIA	Meter BPM	BHT	Injec tion Gradient	Remarks
14:45	39	53		0	99	0.000	Trendline 1 Data: Buildup to Frac
15:23	97	111		3.1	90	0.000	
15:27	165	179		5	88.5	0.000	
16:25	316	330	1707	7.5	88	0.514	
16:54	486	500	1844	9.2	88.7	0.555	
17:24	739	753	2040	11.5	89.6	0.614	
17:55	1019	1033	2264	13.4	90.3	0.682	
18:25	1324	1338	2484	16	90.7	0.748	
18:55	1575	1589	2673	17.7	91	0.805	
19:25	1765	1779		20.2	91.2	0.000	
19:55	1881	1895		21.6	91.3	0.000	

Time	Surface PSIG	Surface PSIA	Downhole PSIA	Meter BPM	BHT	Injec tion Gradient	Remarks
14:45	39	53		0	99	0.000	Trendline 2 Data: Post Frac
15:23	97	111		3.1	90	0.000	
15:27	165	179		5	88.5	0.000	
16:25	316	330		7.5	88	0.000	
16:54	486	500		9.2	88.7	0.000	
17:24	739	753		11.5	89.6	0.000	
17:55	1019	1033		13.4	90.3	0.000	
18:25	1324	1338		16	90.7	0.000	
18:55	1575	1589		17.7	91	0.000	
19:25	1765	1779	2758	20.2	91.2	0.831	
19:55	1881	1895	2798	21.6	91.3	0.843	

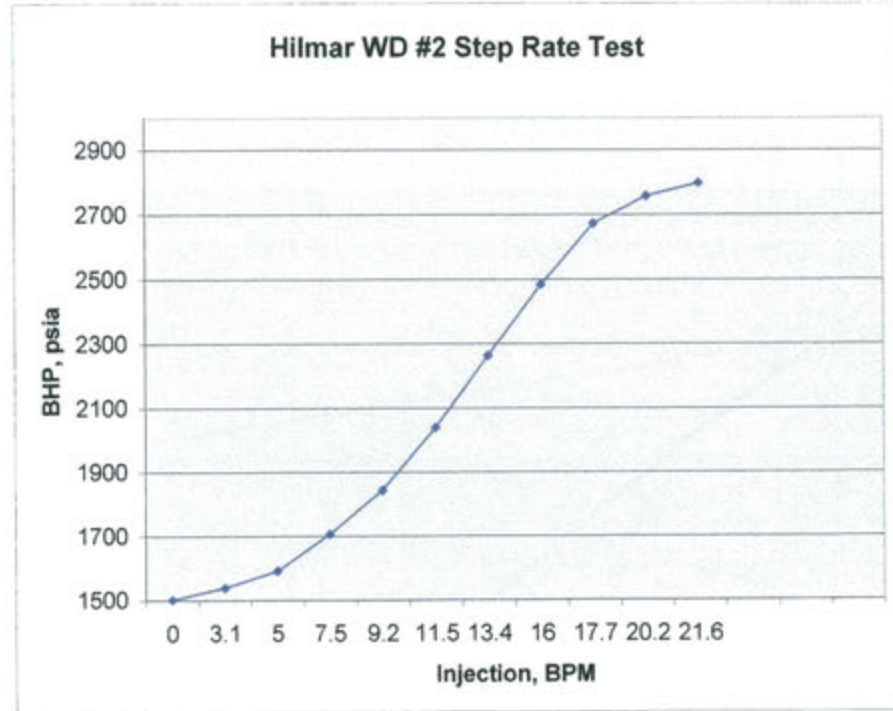

Hilmar WD #2 Step Rate Test

